

# INTERNATIONAL STANDARD VALVE



ISV



## ISV TRUNNION MOUNTED BALL VALVES

BT3BEU, BT3EU, BT3GU, BT4EU, BT9EU, BT7EU,  
BT3BE, BT3E, BT3G

# International Standard Valve Inc.

## TABLE OF CONTENTS

- Design Standards & Features ..... 3
- ISV Difference ..... 4
- Stem/Seat, and Injection Details ..... 5
- Seat Designs ..... 6
- How to Order ..... 7
- Bolt Body Exploded View. Cl 150-300 ..... 8
- Bolt Body Exploded View. Cl 600,900,1500 ..... 9
- Bolt Body Exploded View. Cl 600,900 150-1500 ... 10
- Bolt Body Exploded View. Cl 2500 ..... 11
- Welded Body Exploded View All Sizes/Class ..... 12
- Dimensional Data CL.150 ..... 13
- Dimensional Data CL.300 ..... 14
- Dimensional Data CL.600 ..... 15
- Dimensional Data CL.900 ..... 16
- Dimensional Data CL.1500 & 2500 ..... 17
- Pressure Temperature Chart ..... 18
- Metal Seated and Cryogenic Designs ..... 19

International Standard Valves headquarters is located in Stafford, Texas, a Houston suburb, near the center of the world’s largest collection of oil and gas headquarters for exploration, production, and pipelines, so therefore also a major design center for the most prestigious engineering contractors in the world.

Our team of design, manufacturing, and quality engineers have over 100 years combined experience in the Valve Industry, allowing us to make deliberate and proven decisions to advance ISV forward at a remarkable pace.

Our 78,500 sq. ft. plant houses equipment utilizing the latest technologies for assembly, and testing. It is the hub for our engineering, manufacturing, sales, and warehousing.

Bearing in mind that the market necessitates shortened lead times; ISV has a comprehensive and massive inventory of components to build our world class products, allowing minimal lead times in most cases.

All ISV bolted body and welded pipeline style 3 PC trunnion ball valves are designed to meet or exceed the demands of the oil and gas processing industries, gas gathering, transmission, storage, distribution, LNG, petrochemical, and related industries.

Our valves are utilized in both on shore and in off shore applications; and both above ground and buried applications.

Each employee at ISV, from the shop floor, to the sales department, and on through shipping, knows that they are an integral part of a very special exemplary team where everyone in the company’s first priority is superior customer service!

## STATE-OF-THE-ART STAFFORD, TEXAS FACILITY



6D-1228

ISO 9001, API Q1 Certified  
API 6D Monogrammed in Stafford, TX



# ISV Series BT

## Standard Design Features

Two or three piece design, Bolted or Welded Body, Forged materials of construction, a variety of Seat and Seal options. Trunnion mounted. RF, RTJ or Buttweld end connections. Lever Gear operators, Pneumatic, Electric or Hydraulic actuation.

**Size Range:**  
2" through 42"

**ASME Pressure Class 150 through 2500**  
Reduced & Full Ports

### Design Standards

- API Monogrammed
- API 6D: Specification for Pipeline and Piping Valves
- API 607/ISO 10497: Fire Test for Quarter-Turn Valves and Valves Equipped with Nonmetallic Seats
- API 608: Metal Ball Valves – Flanged, Threaded, and Welding Ends
- API 641: Type Testing of Quarter-Turn Valves for Fugitive Emissions
- API 20E: Alloy and Carbon Steel Bolting for Use in the Petroleum and Natural Gas Industries
- API Q1: Specification for Quality Management System Requirements for Manufacturing Organizations for the Petroleum and Natural Gas Industries
- ASME B16.10: Face-to-Face and End-to-End Dimensions of Valves
- ASME B16.25: Buttwelding Ends
- ASME B16.34: Valves – Flanged, Threaded and Welding End
- ASME B16.47: Large Diameter Steel Flanges: NPS 26 through NPS 60, Metric/Inch Standard
- ASME B16.5: Pipe Flanges and Flanged Fittings: NPS ½ through NPS 24, Metric/Inch Standard
- ASME B31.1: Power Piping
- ASME B31.3: Process Piping
- ASME B31.4: Pipeline Transportation for Liquids and Slurries
- ASME B31.8: Gas Transmission and Distribution Piping Systems
- MSS SP-44: Steel Pipeline Flanges
- NACE MR0175/ISO 15156: Petroleum and Natural Gas Industries – Materials for Use in H<sub>2</sub>S-containing Environments in Oil and Gas Production
- PED 2014/68/EU: Pressure Equipment Directive

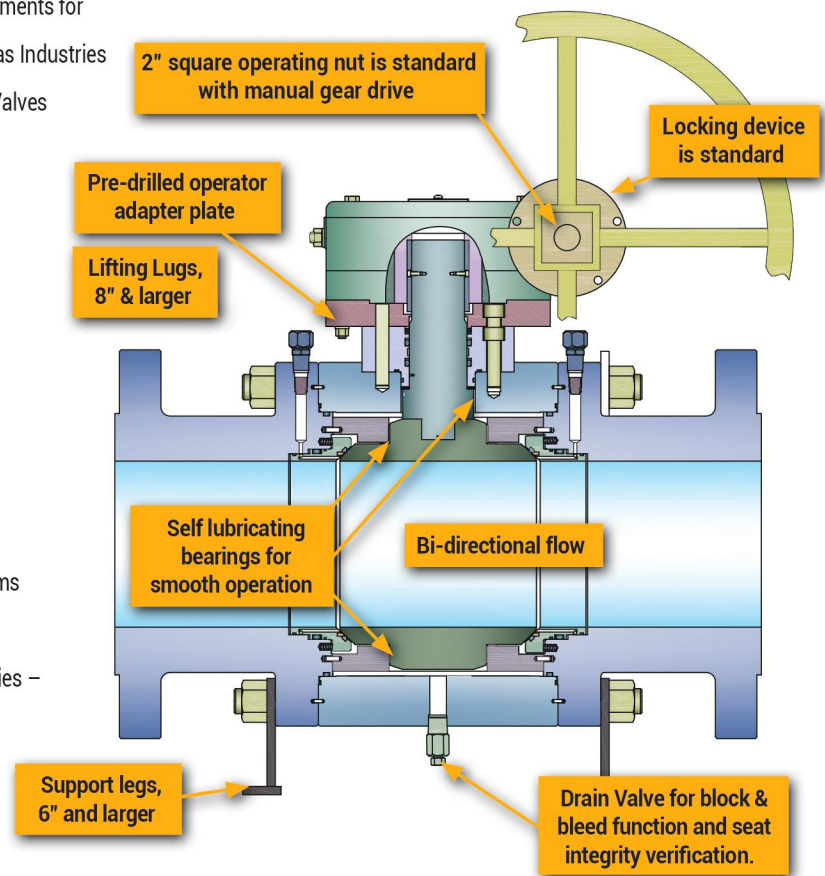

### Design Features

- Anti-Static, Anti Blow-Out Stem Design
- Double Block and Bleed Capacity
- Emergency Sealant Injection System
- Metal Contact for Fire-Safe Seat Sealing
- Rugged Polymeric Seat Inserts
- Solid Forged Ball
- Static Secondary Body Graphite Fire-Safe Seals
- Trunnion Supported Ball Design for Lower Torque

### Typical Configuration

Size 6" - 8" full port, bolted body shown. Welded body design is similar as applicable.

# The ISV Difference



## With ISV's Trunnion Mounted Ball Valves, our standard features are others special options:

- Double block and bleed in the open position that allows the integrity of the valve seats to be checked without interrupting product flow.
- Spiral wound fire-safe gaskets are used on all exterior joints (end caps, glands, trunnions) instead of inferior graphite rope seals.
- True fire-safe piston action seat design includes graphite fire proof seals on the OD of the seat assembly.
- ENP plating on the trunnion bearing plates and gland adapter plate to resist corrosion.
- Numerous solid pins between adapter plate, gland, and body increasing rigidity, instead of weaker split pins.
- Stem thrust washers are metallic with PTFE, which provides lower torque and longer life.
- Dual stem seals on 6" valves and larger.
- Valve design allows for interchangeability of SPE and DPE seat designs during manufacturing.
- ISV standard o-rings are low temperature HNBR, good to -50 F.
- Environmental compliance assured by low emission design in accordance with API 641.
- All ISV Trunnion Mounted Ball Valves are API 6D Monogrammed.
- ASME B16.34 Compliant.



# ISV Series BT3EU, BT3GU, BT3E, BT3G

## Standard Design Features

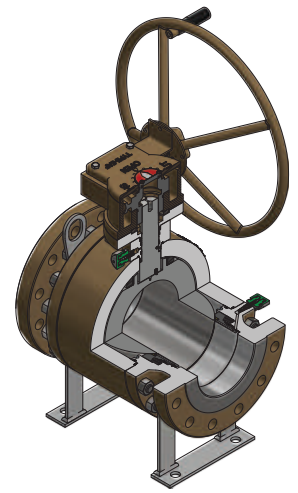

### STEM DETAIL AND EMERGENCY SEAT SEALANT INJECTION SYSTEM

#### SIDE VIEW

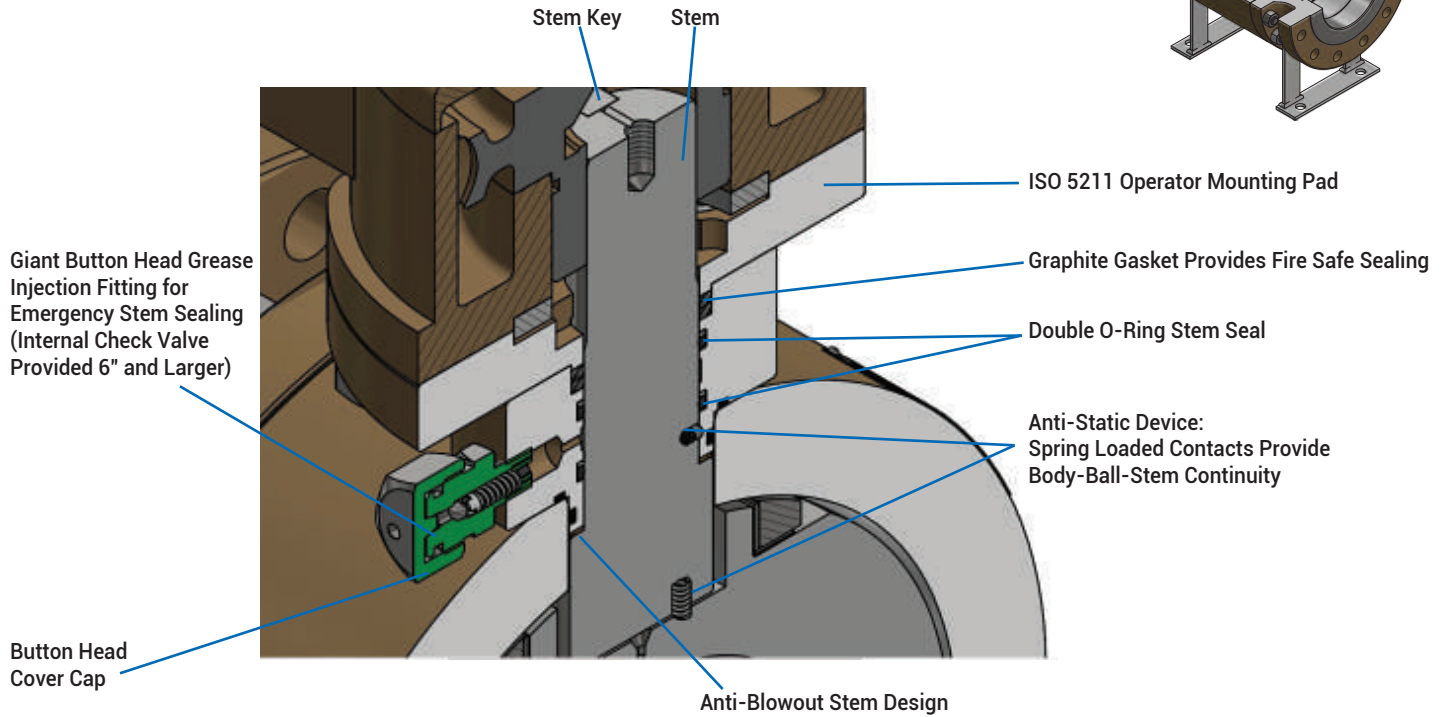

### SEAT DETAIL & EMERGENCY SEAT SEALANT INJECTION SYSTEM

#### TOP VIEW

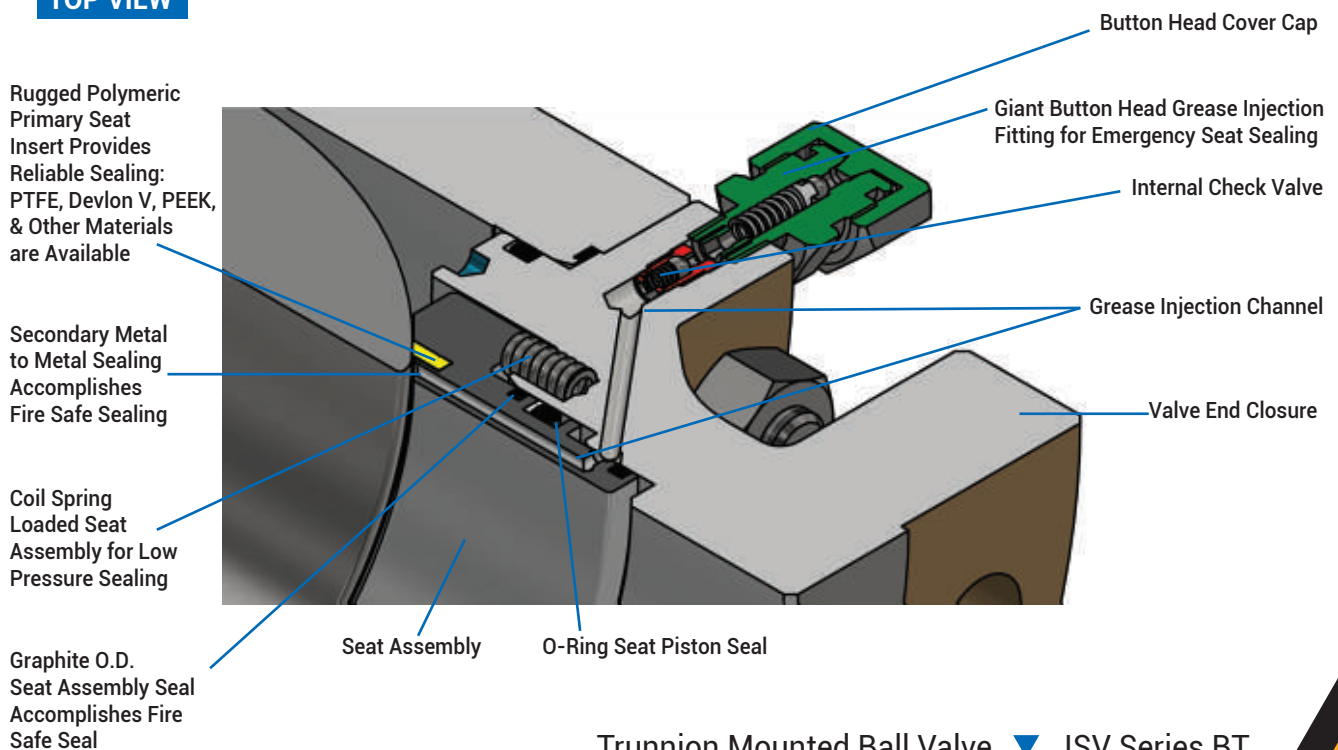

# ISV Series BT

## Seat Design Details

### DBB: DOUBLE BLOCK AND BLEED

Valve seat configuration is SPE x SPE. Single Piston Effect x Single Piston Effect.  
Both valve seats are single directional sealing.

- Each seat automatically self-relieves excessive internal body cavity pressure that is usually created by thermal media expansion between the two seats.
- The excessive cavity pressure relieves to the low pressure side (downstream) on DBB valves.
- Drain valve is provided at the lowest possible point on the valve body to facilitate double block & bleed functionality.

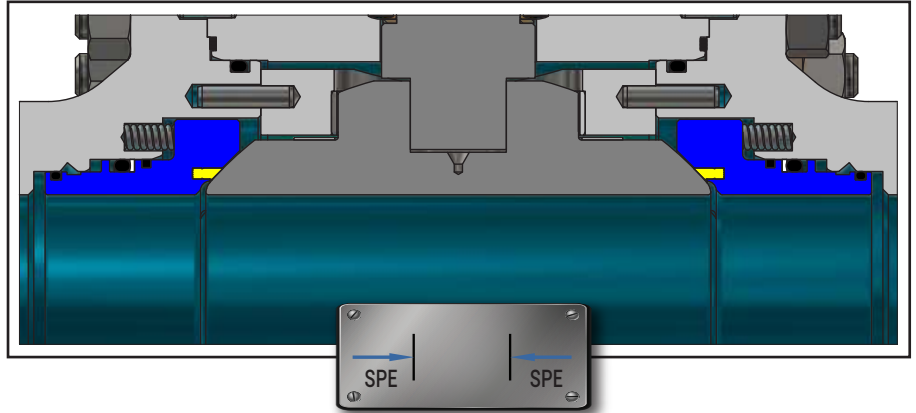

### DIB-1: DOUBLE ISOLATION AND BLEED (TYPE 1)

Valve seat configuration is DPE x DPE. Double Piston Effect x Double Piston Effect.  
Both valve seats are double directional sealing.

- Each DPE seat is designed to seal in either flow direction. DPE seats are NON-SELF-RELIEVING designed.
- Excessive pressure in the body cavity may require an optionally installed pressure relief mechanism such as an externally applied Differential Thermal Relief system (DTR).
- DTR systems can be configured to channel excessive body cavity pressure to a predetermined side of the valve or piping system.
- Drain valve is provided at the lowest possible point on the valve body to facilitate double block & bleed functionality.

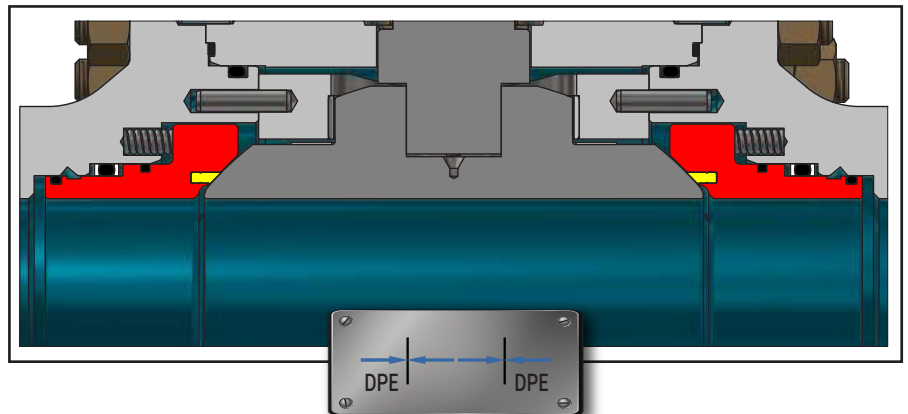

### DIB-2: DOUBLE ISOLATION AND BLEED (TYPE 2)

Valve seat configuration is SPE x DPE. Single Piston Effect x Double Piston Effect.  
One valve seat is single directional sealing and the other valve seat is double directional sealing.

- The SPE seat is designed to SELF-RELIEVE the valve of excessive pressure in the body cavity.
- The DPE seat is designed to seal in either flow direction. DPE seats are NON-SELF-RELIEVING designed.
- An external Differential Thermal Relief system (DTR) may be optionally installed upon specific request.
- DTR systems can be configured to channel excessive body cavity pressure to a predetermined side of the valve or piping system.
- Drain valve is provided at the lowest possible point on the valve body to facilitate double block & bleed functionality.

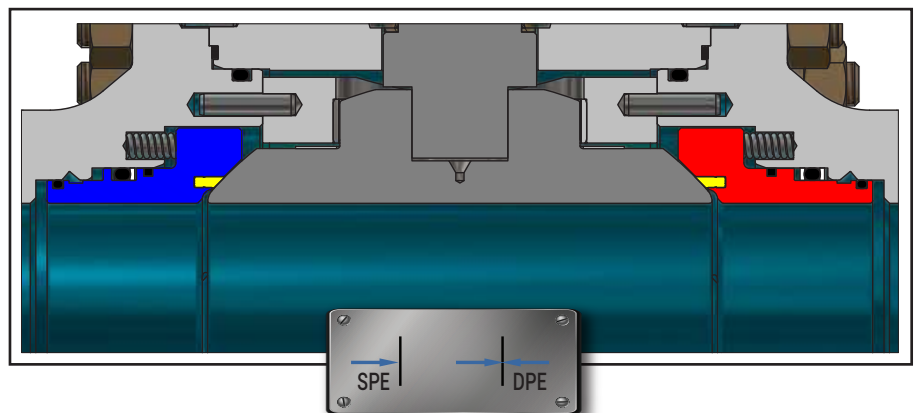



# ISV Series BT

## How to Order

**EXAMPLE MODEL NUMBER:** BT3EU2-F060-1110RF-NH-NFG

**DESCRIPTION:** CL 600, Full Port, Raised Face Flanged Ends

**DESIGN:** 3 pc Bolted Body **BODY:** A105N **TRIM:** Carbon Steel +3MIL ENP **SEAT DESIGN:** Double Isolation and Bleed (DIB-2)

**SEATS:** Nylon inserts **SEALS:** HNBR **ACTION:** Gear op **CERTIFIED:** NACE, Fire safe tested

<b>BT</b>	<b>3</b>	<b>EU</b>	<b>2</b>	-	<b>F</b>	<b>060</b>	-	<b>11</b>	<b>10</b>	<b>RF</b>	-	<b>N</b>	<b>H</b>	-	<b>NF</b>	<b>G</b>
<b>1</b>	<b>2</b>	<b>3</b>	<b>4</b>		<b>5</b>	<b>6</b>		<b>7</b>	<b>8</b>	<b>9</b>		<b>10</b>	<b>11</b>		<b>12</b>	<b>13</b>

1 Valve Type		2 Service/Design Style		3 Body Design		4 Seat Design		5 Bore	
Code	Type	Code	Design style	Code	Body style	Code	Seat Design	Code	Port
BT	Trunnion	1	Adjustable Stem Packing	B	2 pc Bolted Body		SPE x SPE (DBB)	R	Reduced
		3	O-Ring Stem Seal	E	3 pc Bolted Body	1	DPE x DPE (DIB-1)	F	Full
		4	Metal Seated	G	3 pc Welded Body	2	SPE x DPE (DIB-2)		
		5	Weld Overlay Body	U	USA Production				
		7	Cryogenic Service						
		9	Severe Service						

6 Pressure Rating (ASME)		7 Body Material		8 Trim Material		9 End Connections	
Code	Class	Code	Material	Code	Material	Code	Ends
015	150	10	Carbon Steel	10	C.S. + ENP	RF	Flg-RF
030	300	11	A105N	19	XM19	RJ	Flg-RTJ
060	600	21	A105N / LF2 (-20 Deg. F. Service)	20	LT. C.S. + ENP (-50 Deg. F. Service)	FF	Flg-FF
090	900	22	LF2 (-50 Deg. F. Service)	34	304SS / CF8	WW	WE x WE
150	1500	34	304SS	36	316SS / CF8M	WF	WE x RF
250	2500	36	316SS	51	F51 / 318	WJ	WE x RTJ
		51	F51 / 318	60	Inconel 625	HH	Hub x Hub
		60	Inconel	61	410SS		
		91	CS + Inconel Seat Pocket	62	Inconel 825		
		92	CS + SS Seat Pocket	71	Monel		
		95	CS + ENP Internal	72	Alloy 20		
		A2	Alloy 20	73	Hastelloy		
		H1	Hastelloy C				

10 Seat Insert		11 Body Seals		12 NACE/Fire Safe		13 Operator	
Code	Material	Code	Material	Code	Description	Code	Description
N	Nylon	V	FKM (Viton)	NF	NACE Compliant, Fire Safe	L	Locking Lever
T	PTFE	H	HNBR	NW	NACE Compliant, Non Fire Safe Tested	B	Bare Stem
D	Devlon V	L	Low Temp	WF	Without NACE, Fire Safe	S	Spring Return Lever
H	HNBR	K	PCTFE	WW	Without NACE, Non Fire Safe Tested	G	Locking Manual Gear
R	RPTFE	G	Graphite			H	Non Locking Lever
C	TFM 4215	T	PTFE			C	Chain Wheel
K	PCTFE	M	TFM			O	Oval Hand Wheel
P	PEEK	E	EPDM			A	Actuated
V	FKM (Viton)	W	FFKM			E1	Pinion Shaft Extension
1	Tung. Carbide	9	PTFE - Lip Seal			E2	High Head Extension

**NOTE:** Materials of construction are NACE compliant unless otherwise specified by customer.

# ISV Series BT3B

## 2 pc Bolted Body, Exploded View, Component parts

CLASS  
150 & 300  
2" - 4"

ITEM NO.	PART DESCRIPTION	ITEM NO.	PART DESCRIPTION	ITEM NO.	PART DESCRIPTION
1	Body	12	O-Ring, Trunnion	28	Studs (End Cap/Body)
2	End Cap	13	Backup Ring, Stem	29	Hex Nut
3	Ball	14	Body/End Cap Gasket	30	Cap Screws (Top Plate/Gland)
4	Stem	15	Gland Gasket	31	Cap Screws (Gland/Body)
5	Trunnion (Trunnion Plate on 4")	16	Trunnion Gasket	32	Cap Screws (Trunnion/Body)
6	Seat	17	Stem Packing	33	Internal Check Valve, Seat
6.1	Seat Ring	18	Thrust Washer, Stem	34	Stem Injection Fitting
6.2	Seat Insert	19	Spacer-Ball Lower	35	Seat Injection Fitting
6.3	O-Ring, Seat	20	Bearing Ball-Upper	36	Drain Valve
6.4	Backup Ring, Seat	21	Bearing Ball-Lower	37	T Lever Adapter
6.5	Gasket Seat	22	Stem Key Pin	38	Handle
7	Gland	23	Alignment Pin, Body/End Cap	39	Lock Screw
8	Top Plate	24	Locating Pin, Body/End Cap	40	Bolt
9	Body/End Cap	25	Coil Spring, Seat	41	Set Screw-Stem Key
10	O-Ring, Stem	26	Spring, Anti-Static	42	Nut, Lock Device
11	O-Ring, Gland	27	Key	43	Indicator Plate

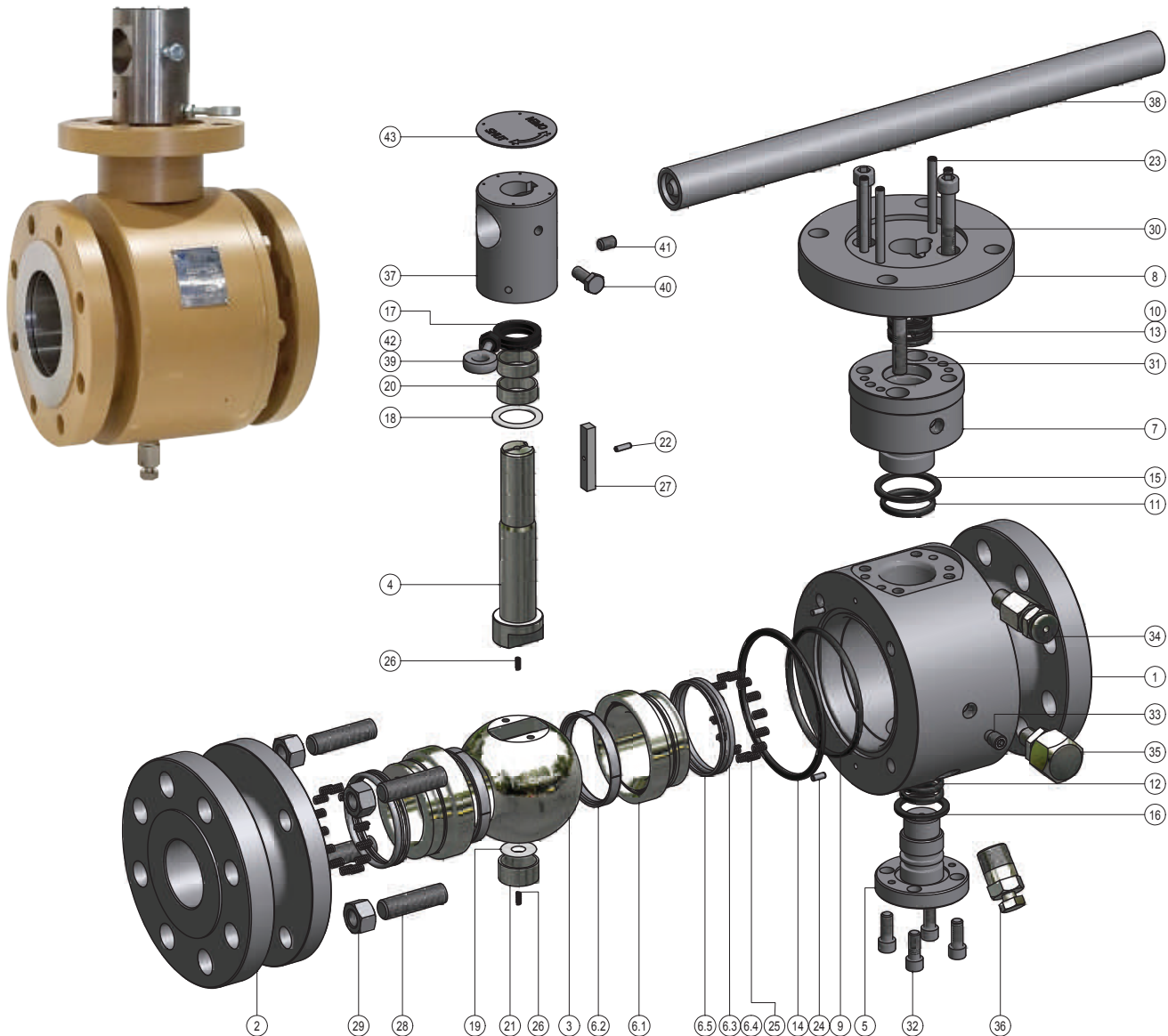



# ISV Series BT3E

## 3 pc Bolted Body, Exploded View, Component parts

CLASS  
600,900,1500  
2" & 3"

ITEM NO.	PART DESCRIPTION
1	Body
2	End Cap
3	Ball
4	Stem
5	Trunnion
6	Seat
6.1	Seat Ring
6.2	Seat Insert
6.3	O-Ring, Seat
6.4	Backup Ring, Seat
6.5	Gasket Seat
7	Gland
8	Top Plate
9	O-Ring, End Cap
10	O-Ring Stem
11	O-Ring,Gland

ITEM NO.	PART DESCRIPTION
12	O-Ring Trunnion
13	Backup Ring, Stem
14	Gasket Body-Endcap
15	Gasket, Gland
16	Gasket, Trunnion
17	Stem Packing
18	Thrust Washer
19	Spacer-Ball-Lower
20	Bearing Ball-Upper
21	Bearing Ball-Upper
22	Stem Key Pin
23	Alignment Pin
24	Body/End Cap Pin
25	Spring, Anti-Static
26	Spring, Seat
27	Key

ITEM NO.	PART DESCRIPTION
28	Studs (End Cap/Body)
29	Nut
30	Cap Screw (Top Plate/Gland)
31	Cap Screw (Gland/Body)
32	Cap Screw (Trunnion/Body)
33	Internal Check Valve, Seat
34	Injection Fitting, Stem
35	Injection Fitting, Seat
36	Drain Valve
37	Lever Adapter
38	Handle
39	Lock Screw
40	Bolt
41	Set Screw-Stem Key
42	Nut, Lock Device
43	Indicator Plate

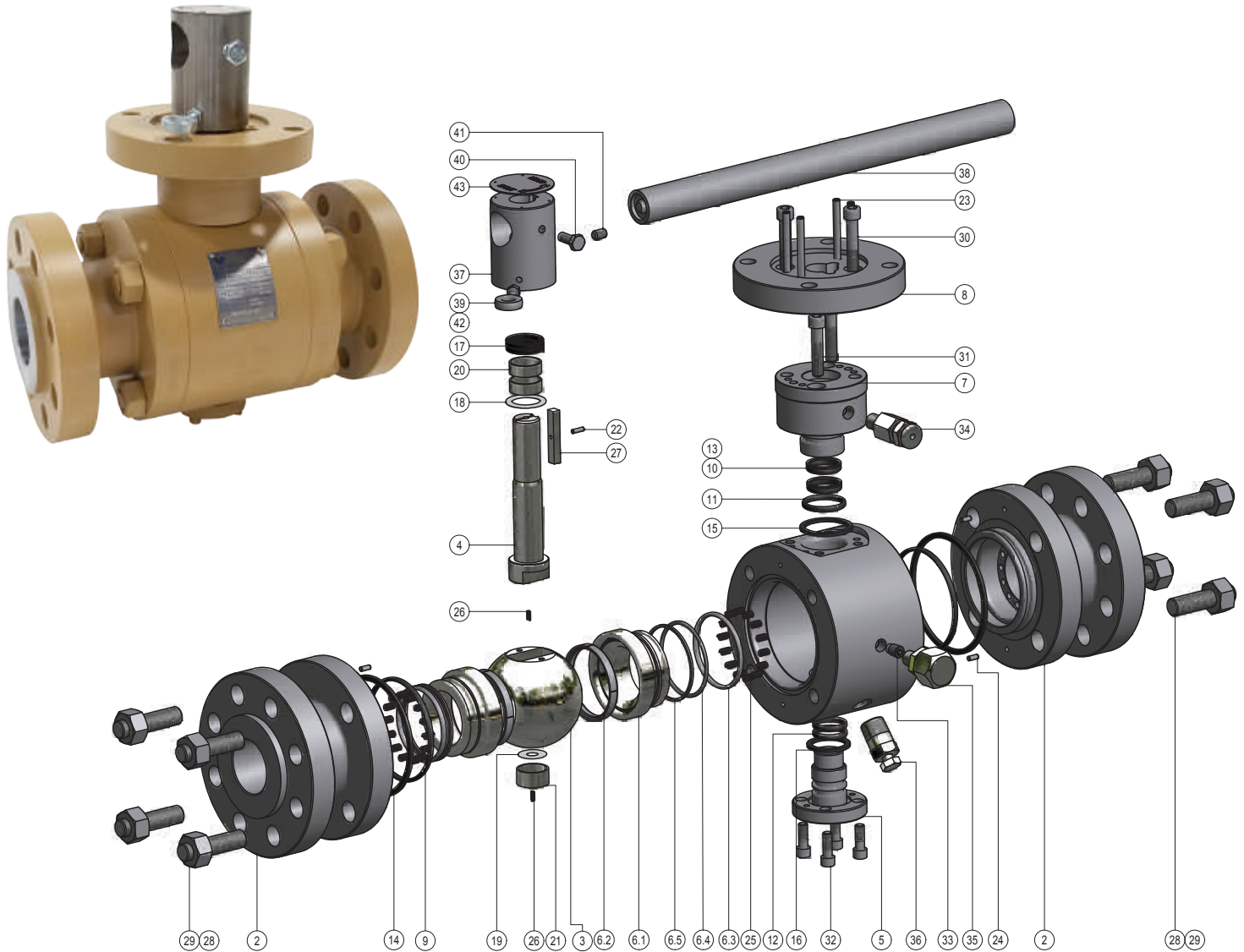

# ISV Series BT3E

## 3 pc Bolted Body, Exploded View, Component parts

CLASS  
600, 900  
4"

CLASS  
150 - 1500  
6" - 42"

ITEM NO.	PART DESCRIPTION
1	Valve Body
2	End Cap
3	Ball
4	Stem
5	Trunnion Plate
6	Seat
6.1	Seat
6.2	Delta Ring
6.3	Seat Insert
6.4	O-Ring, Seat
6.5	O-Ring Seat, (Secondary)
6.6	Backup Ring, Seat
6.7	Gasket Seat
7	Gland
8	Top Plate
9	O-Ring, End Cap/Body
10	O-Ring Stem
11	O-Ring Gland

ITEM NO.	PART DESCRIPTION
12	Backup Ring, Stem
13	Gasket, Body/End Cap
14	Gasket Gland
15	Stem Packing
16	Thrust Washer, Stem
17	Spacer-Ball-Upper
18	Spacer-Ball-Lower
19	Bearing Ball
20	Pin, Trunnion Plate
21	Body/End Cap Pin
22	Alignment Pin
23	Spring, Seat
24	Spring, Anti-Static
25	Anti-Static Spring Device
26	Key
27	Studs (Support Leg)
28	Studs (End Cap/Body)
29	Nut

ITEM NO.	PART DESCRIPTION
30	Cap Screw (Top Plate/Gland)
31	Cap Screw (Gland/Body)
32	Set Screw, Stem Key
33	Internal Check Valve, Stem
34	Internal Check Valve, Seat
35	Injection Fitting, Stem
36	Injection Fitting, Seat
37	Drain Valve
38	Vent Plug
39	Support Leg
40	Lifting Eye
41	Vent Plug
44	Gear Box
45	Stud, Gear
46	Nut, Gear
47	Washer, Gear

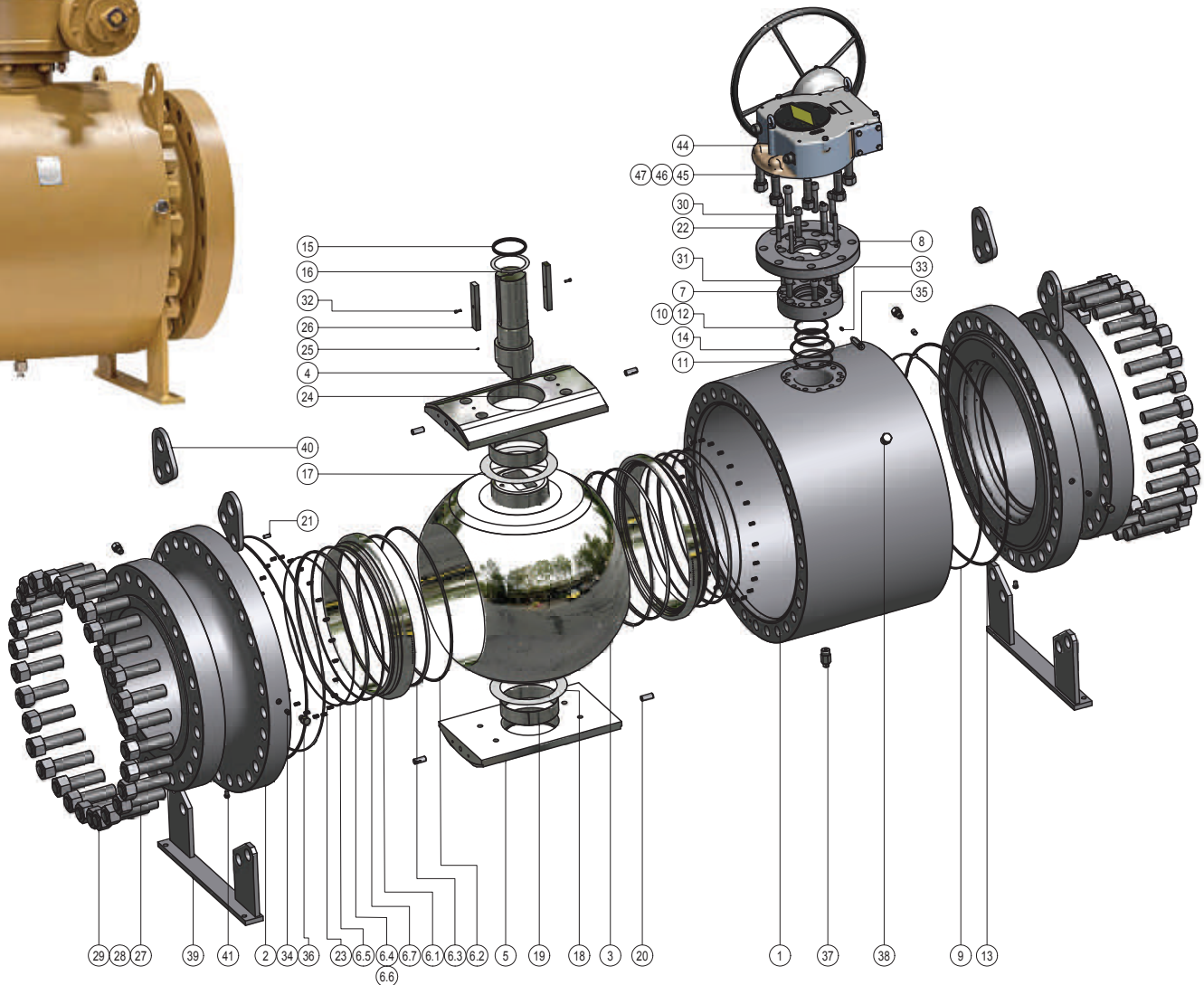



# ISV Series BT3E

## 3 pc Bolted Body, Exploded View, Component parts

ALL CLASS  
2500

ITEM NO.	PART DESCRIPTION
1	Valve Body
2	End Cap
3	Ball
4	Stem
5	Trunnion Plate
6	Seat
7	Seat
7.1	Seat Ring
7.2	Seat Insert
7.3	Gasket Seal
7.4	Backup Ring, Seal
7.5	O-Ring Seat
7.6	O-Ring Seat, (Secondary)
8	Gland
9	Top Plate
10	O-Ring, End Cap
11	O-Ring, End Cap
12	O-Ring, Gland
13	O-Ring, Stem

ITEM NO.	PART DESCRIPTION
14	Backup Ring, Body/Endcap
15	Backup Ring, Gland
16	Backup Ring, Stem
17	Stem Packing
18	Gasket Body/End Cap
19	Gasket, Gland
20	Thrust Washer, Stem
21	Spacer-Ball-Upper
22	Spacer-Ball-Lower
23	Bearing Ball
24	Pin-Trunnion Plate
25	Body/End Cap Pin
26	Internal Threaded Pin
27	Alignment Pin
28	Spring, Seat
29	Spring-Anti-Static
30	Key
31	Studs (End Cap/Body)
32	Studs (Support Leg)

ITEM NO.	PART DESCRIPTION
33	Studs (Lifting Lug)
34	Nut
35	Cap Screw (Gland/Body)
36	Cap Screw (Top Pale/Gland)
37	Set Screw-Stem Key
38	Internal Check Valve-Stem
39	Internal Check Valve-Seat
40	Injection Fitting-Stem
41	Injection Fitting-Seat
42	Drain Valve
43	Vent Plug
44	Support Leg
45	Lifting Eye
46	Vent Plug
47	Gear Box
48	Stud-Gear
49	Nut-Gear
50	Washer-Gear

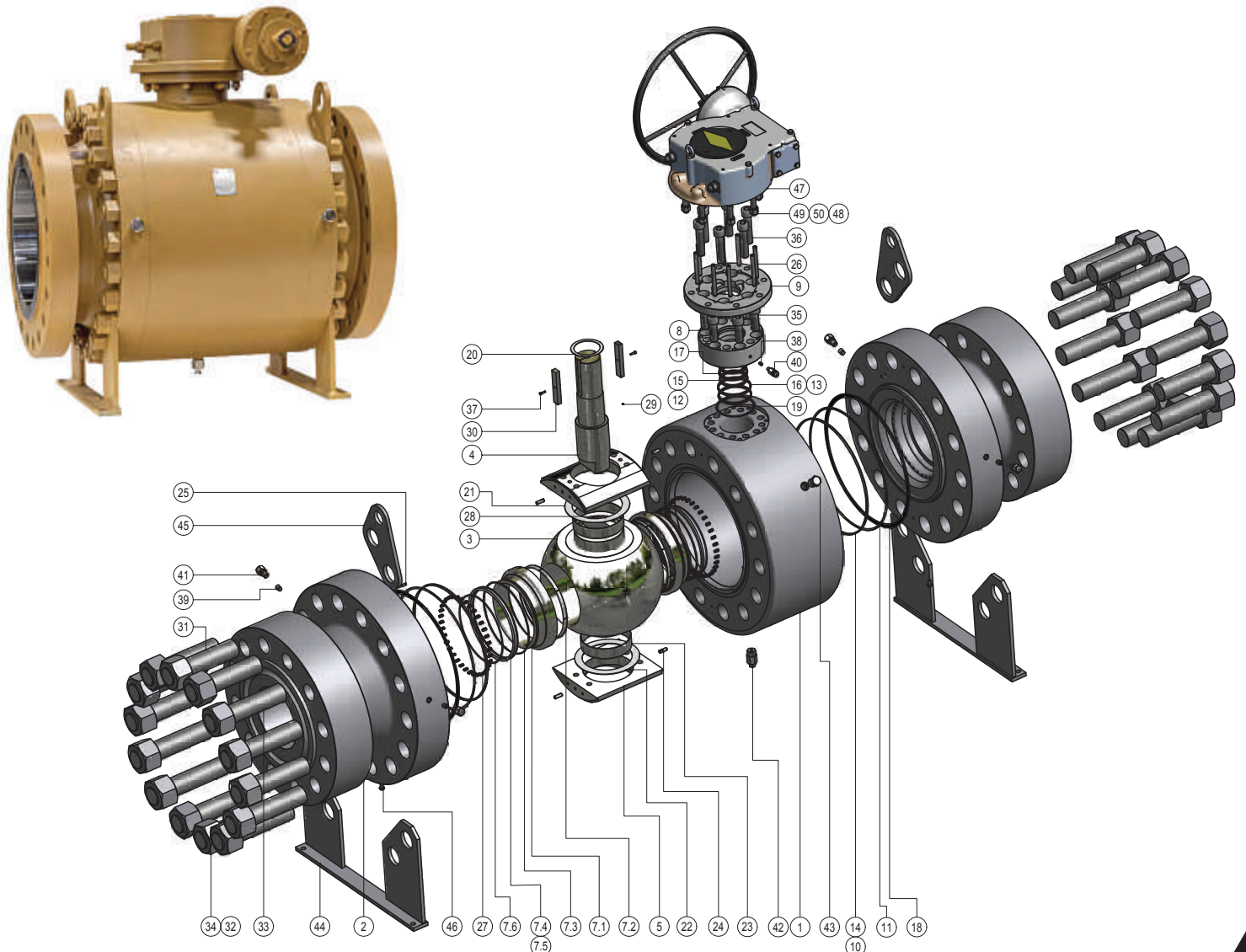

# ISV Series BT3G

## Fully Welded Body, Exploded View, Component parts

ALL CLASSES/  
SIZES

ITEM NO.	PART DESCRIPTION	ITEM NO.	PART DESCRIPTION	ITEM NO.	PART DESCRIPTION
1	Valve Body	9	Gasket Gland	25	Spring Seat
2	Left Body	10	O-Ring, Stem	26	Spring, Anti Static
3	Ball	11	O-Ring Seal	27	Anti-Static Spring Device
4	Stem	12	O-Ring Seal	28	Key
5	Trunnion Plate	13	O-Ring Seal	29	Cap Screw (Top Plate/Gland)
6	Seat	14	Gasket Gland	30	Key
6.1	Seat Support	15	Stem Packing	31	Internal Check Valve, Stem
6.2	Delta Ring	16	Backup Ring, Stem	32	Internal Check Valve, Seat
6.3	Seat Insert	17	O-Ring Backup	33	Injection Fitting, Stem
6.4	O-Ring Seat	18	Spacer-Ball-Upper	34	Injection Fitting, Seat
6.5	O-Ring Seat, (Secondary)	19	Spacer Ball, Lower	35	Drain Valve
6.6	Backup Ring, Seat	20	Bearing Ball	36	Vent Plug
6.7	Gasket Seat	21	Thrust Washer	37	Support Leg
6.8	Spring Pin	22	Sliding Bearing (Composite)	38	Lifting Eye
7	Gland	23	Locating Pin	39	Pressure Relief Valve
8	Top plate	24	Alignment Pin	40	Ball Valve

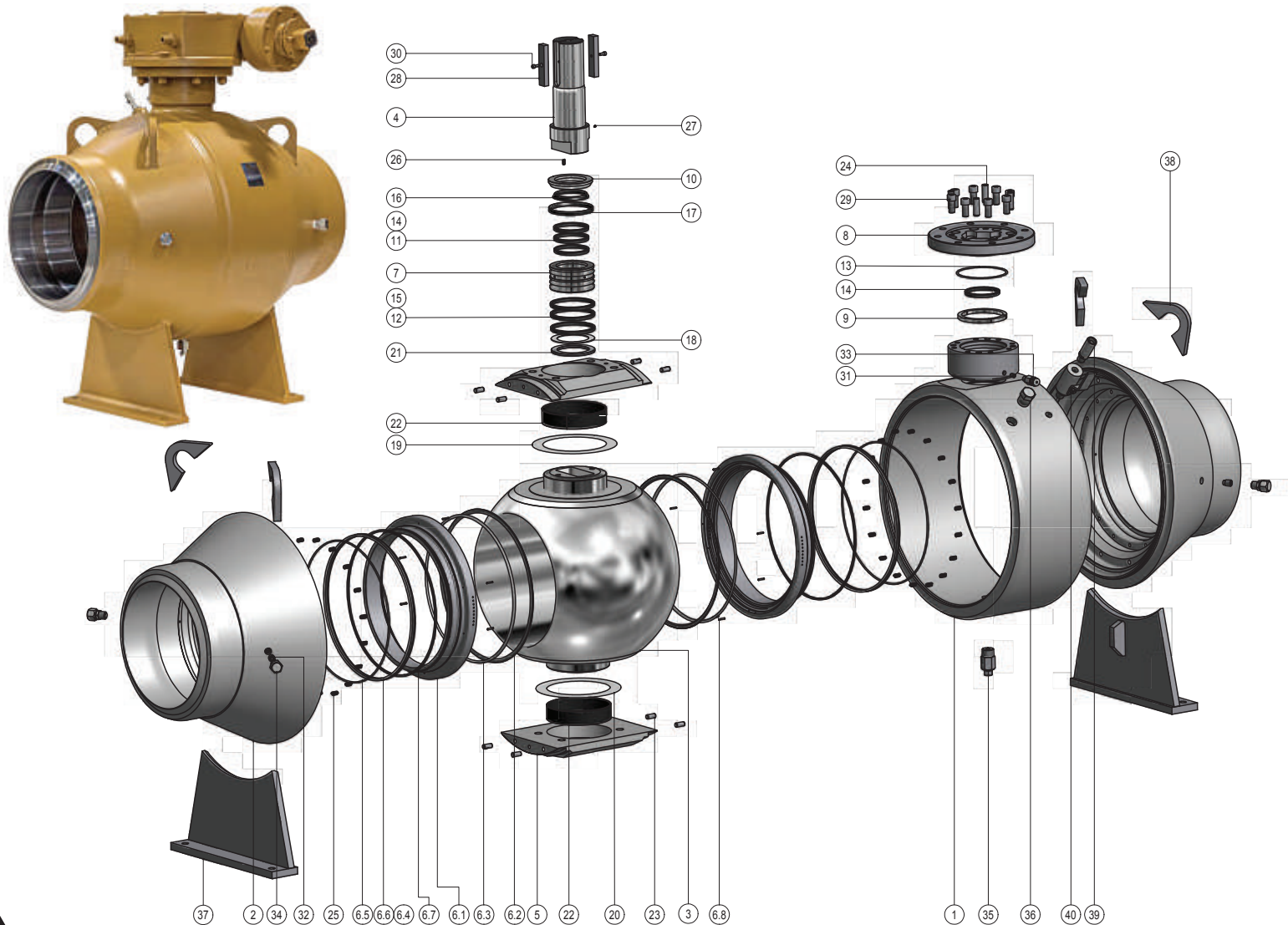



# ISV Series BT

## Dimensional Data Class 150

**BOLTED OR WELDED DESIGN**

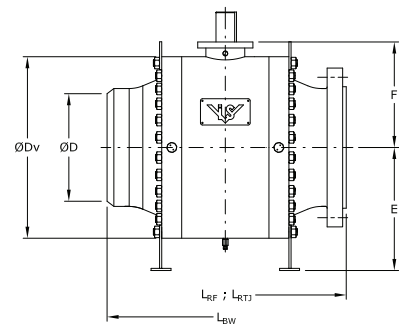

Class 150		Inches							Weight (lbs)		
NPS	DN	D	L RF	L RTJ	L BW	Dv	E	F	RF, RTJ	BW	Cv
2"	50.00	2.00	7.00	7.50	8.50	6.00	3.90	4.10	62.00	48.00	490
3" x 2"	80 x 50	3.0 x 2.0	8.00	8.50	11.13	6.00	3.90	4.10	68.00	57.00	200
3"	80.00	3.00	8.00	8.50	11.13	7.40	4.90	6.10	117.00	106.00	1320
4" x 3"	100 x 80	4.0 x 3.0	9.00	9.50	12.00	7.40	4.90	6.10	139.00	115.00	550
4"	100.00	4.00	9.00	9.50	12.00	9.00	6.30	7.90	198.00	174.00	2450
6" x 4"	150 x 100	6.0 x 4.0	15.50	16.00	18.00	9.00	6.30	7.90	225.00	170.00	785
6"	150.00	6.00	15.50	16.00	18.00	12.00	7.20	9.80	359.00	304.00	5200
8" x 6"	200 x 150	8.0 x 6.0	18.00	18.50	20.50	12.00	7.30	9.80	414.00	359.00	2100
8"	200.00	8.00	18.00	18.50	20.50	15.40	8.70	10.90	551.00	496.00	10300
10" x 8"	250 x 200	10.0 x 8.0	21.00	21.50	22.00	15.40	8.70	10.90	639.00	564.00	4200
10"	250.00	10.00	21.00	21.50	22.00	18.40	11.00	12.70	849.00	774.00	17150
12" x 10"	300 x 250	12.0 x 10.0	24.00	24.50	25.00	18.40	11.00	12.70	1025.00	915.00	7200
14" x 10"	350 x 250	13.3 x 10.0	27.00	27.50	30.00	18.40	11.00	12.70	1153.00	1010.00	*
12"	300.00	12.00	24.00	24.50	25.00	21.30	11.90	13.40	1239.00	1129.00	25800
14" x 12"	350 x 300	13.3 x 12.0	27.00	27.50	30.00	21.30	11.90	13.40	1371.00	1228.00	13300
16" x 12"	400 x 300	15.2 x 12.0	30.00	30.50	33.00	21.30	11.90	13.40	1559.00	1184.00	*
14"	350.00	13.30	27.00	27.50	30.00	23.90	13.00	14.80	1687.00	1544.00	31200
16" x 14"	400 x 350	15.2 x 13.3	30.00	30.50	33.00	23.90	13.00	14.80	1830.00	1455.00	14500
16"	400.00	15.20	30.00	30.50	33.00	26.60	14.00	16.10	2271.00	1896.00	42400
18" x 16"	450 x 400	17.2 x 15.2	34.00	34.50	36.00	26.60	14.00	16.10	2381.00	1896.00	20000
20" x 16"	500 x 400	19.3 x 15.2	36.00	36.50	39.00	26.60	14.00	16.10	2579.00	2416.00	*
18"	450.00	17.20	34.00	34.50	36.00	29.60	15.40	17.30	2685.00	2380.00	56150
20" x 18"	500 x 450	19.3 x 17.2	36.00	36.50	39.00	29.60	15.40	17.30	2862.00	2699.00	27600
20"	500.00	19.30	36.00	36.50	39.00	33.30	16.90	19.50	3964.00	3801.00	73000
24" x 20"	600 x 500	23.3 x 19.3	42.00	42.50	45.00	33.30	16.90	19.50	4515.00	4272.00	27500
24"	600.00	23.30	42.00	42.50	45.00	39.80	20.50	23.00	6828.00	6585.00	110050
30" x 24"	750 x 600	29.0 x 23.3	51.00	-	55.00	39.80	20.50	23.00	7379.00	6702.00	48960
26"	650.00	25.00	45.00	-	49.00	42.10	22.00	24.80	8128.00	7621.00	114450
28"	700.00	27.00	49.00	-	53.00	44.90	25.60	25.40	9910.00	*	134100
30"	750.00	29.00	51.00	-	55.00	48.00	27.60	27.20	11530.00	10853.00	158500
36" x 30"	900 x 750	34.5 x 29.0	60.00	-	68.00	48.00	27.60	27.20	13911.00	12753.00	89830
32"	800.00	30.70	54.00	-	60.00	51.60	29.30	29.10	15036.00	*	179000
34"	850.00	32.80	58.00	-	64.00	54.30	30.50	29.90	17218.00	16226.00	203600
36"	900.00	34.50	60.00	-	68.00	56.70	31.70	31.90	19423.00	18265.00	229100

# ISV Series BT

## Dimensional Data Class 300

**BOLTED OR WELDED DESIGN**

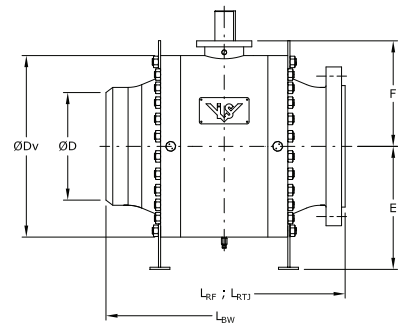

Class 300		Inches							Weight (lbs)		
NPS	DN	D	L RF	L RTJ	L BW	Dv	E	F	RF, RTJ	BW	Cv
2"	50	2.00	8.50	9.13	8.50	6.00	3.90	4.10	64	51	450
3" x 2"	80 x 50	3.0 x 2.0	11.13	11.75	11.13	6.00	3.90	4.10	75	44	195
3"	80	3.00	11.13	11.75	11.13	7.40	4.90	6.10	126	95	1130
4" x 3"	100 x 80	4.0 x 3.0	12.00	12.63	12.00	7.40	4.90	6.10	143	101	540
4"	100	4.00	12.00	12.63	12.00	9.00	6.30	7.90	209	167	2160
6" x 4"	150 x 100	6.0 x 4.0	15.88	16.50	18.00	9.00	6.30	7.90	260	188	770
6"	150	6.00	15.88	16.50	18.00	12.00	8.00	9.80	408	336	5180
8" x 6"	200 x 150	8.0 x 6.0	19.75	20.38	20.50	12.00	8.00	9.80	489	383	2100
8"	200	8.00	19.75	20.38	20.50	15.40	9.10	10.90	633	527	9400
10" x 8"	250 x 200	10.0 x 8.0	22.38	23.00	22.00	15.40	9.10	10.90	655	496	4100
10"	250	10.00	22.38	23.00	22.00	18.80	11.70	13.10	1118	959	16400
12" x 10"	300 x 250	12.0 x 10.0	25.50	26.13	25.00	18.80	11.70	13.10	1316	1096	7100
14" x 10"	350 x 250	13.3 x 10.0	30.00	30.63	30.00	18.80	11.70	13.10	1429	1142	*
12"	300	12.00	25.50	26.13	25.00	21.30	13.10	14.20	1631	1411	25000
14" x 12"	350 x 300	13.3 x 12.0	30.00	30.63	30.00	21.30	13.10	14.20	1808	1521	13250
16" x 12"	400 x 300	15.2 x 12.0	33.00	33.63	33.00	21.30	13.10	14.20	2138	1587	*
14"	350	13.30	30.00	30.63	30.00	24.80	13.80	15.60	2288	2001	29450
16" x 14"	400 x 350	15.2 x 13.3	33.00	33.63	33.00	24.80	13.80	15.60	2491	1940	14450
16"	400	15.20	33.00	33.63	33.00	27.50	15.70	17.00	3148	2597	41750
18" x 16"	450 x 400	17.2 x 15.2	36.00	36.63	36.00	27.50	15.70	17.00	3523	2817	19800
20" x 16"	500 x 400	19.3 x 15.2	39.00	39.75	39.00	27.50	15.70	17.00	3677	3302	*
18"	450	17.20	36.00	36.63	36.00	30.30	16.10	18.10	3532	2826	54260
20" x 18"	500 x 450	19.3 x 17.2	39.00	39.75	39.00	30.30	16.10	18.10	3962	3587	27550
20"	500	19.30	39.00	39.75	39.00	33.70	18.50	19.90	4866	4491	70850
24" x 20"	600 x 500	23.3 x 19.3	45.00	45.88	45.00	33.70	18.50	19.90	5880	5439	27450
22"	550	21.30	43.00	43.88	43.00	37.00	19.10	20.90	6166	5593	*
24"	600	23.30	45.00	45.88	45.00	40.40	21.70	23.20	7650	7209	106950
30" x 24"	750 x 600	29.0 x 23.3	55.00	56.00	55.00	40.40	21.70	23.20	9899	8587	48400
26"	650	25.00	49.00	50.00	49.00	42.70	23.00	25.00	10296	9590	109700
28"	700	27.00	53.00	54.00	53.00	45.30	26.40	25.40	12743	*	129000
30"	750	29.00	55.00	56.00	55.00	48.80	28.70	27.60	14550	13238	152500
36" x 30"	900 x 750	34.5 x 29.0	68.00	69.13	68.00	48.80	28.70	27.60	18056	16014	86880
32"	800	30.70	60.00	61.13	60.00	52.00	30.30	29.50	17505	*	170100
34"	850	32.80	64.00	65.13	64.00	54.80	31.50	30.10	19952	18563	193800
36"	900	34.50	68.00	69.13	68.00	57.10	32.50	31.90	22267	20225	215300

# ISV Series BT

## Dimensional Data Class 600

**BOLTED OR WELDED DESIGN**

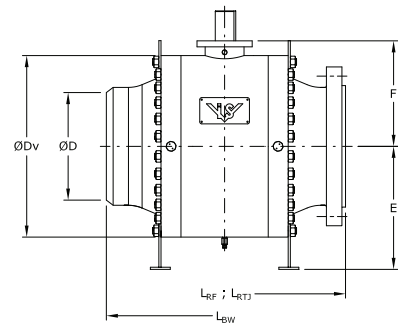

Class 600		Inches							Weight (lbs)		
NPS	DN	D	L RF	L RTJ	L BW	Dv	E	F	RF, RTJ	BW	Cv
2"	50	2.00	11.50	11.63	11.50	6.30	3.90	4.10	73	60	400
3" x 2"	80 x 50	3.0 x 2.0	14.00	14.13	14.00	6.30	3.90	4.10	88	33	190
3"	80	3.00	14.00	14.13	14.00	7.50	5.10	6.50	141	86	1030
4" x 3"	100 x 80	4.0 x 3.0	17.00	17.13	17.00	7.50	5.10	6.50	176	113	540
4"	100	4.00	17.00	17.13	17.00	9.20	6.40	8.30	251	188	1850
6" x 4"	150 x 100	6.0 x 4.0	22.00	22.13	22.00	9.20	6.40	8.30	337	213	740
6"	150	6.00	22.00	22.13	22.00	12.00	8.00	10.00	562	438	4600
8" x 6"	200 x 150	8.0 x 6.0	26.00	26.13	26.00	12.00	8.00	10.00	639	456	2100
8"	200	8.00	26.00	26.13	26.00	15.90	10.10	11.40	1074	891	9000
10" x 8"	250 x 200	10.0 x 8.0	31.00	31.13	31.00	15.90	10.10	11.40	1206	897	4000
10"	250	10.00	31.00	31.13	31.00	19.30	12.20	13.10	1676	1367	14700
12" x 10"	300 x 250	12.0 x 10.0	33.00	33.13	33.00	19.30	12.20	13.10	1786	1431	7100
14" x 10"	350 x 250	13.3 x 10.0	35.00	35.13	35.00	19.30	12.20	13.10	2017	1671	*
12"	300	12.00	33.00	33.13	33.00	22.80	13.80	15.00	2359	2004	22500
14" x 12"	350 x 300	13.3 x 12.0	35.00	35.13	35.00	22.80	13.80	15.00	2513	2167	13200
16" x 12"	400 x 300	15.2 x 12.0	39.00	39.13	39.00	22.80	13.80	15.00	2976	2358	*
14"	350	13.30	35.00	35.13	35.00	24.80	14.20	15.60	2392	2046	27800
16" x 14"	400 x 350	15.2 x 13.3	39.00	39.13	39.00	24.80	14.20	15.60	2884	2266	14320
16"	400	15.20	39.00	39.13	39.00	27.60	16.30	17.00	3366	2748	37350
18" x 16"	450 x 400	17.2 x 15.2	43.00	43.13	43.00	27.60	16.30	17.00	3708	3068	19750
20" x 16"	500 x 400	19.3 x 15.2	47.00	47.25	47.00	27.60	16.30	17.00	4601	3688	*
18"	450	17.20	43.00	43.13	43.00	30.50	16.90	18.50	4623	3983	49930
20" x 18"	500 x 450	19.3 x 17.2	47.00	47.25	47.00	30.50	16.90	18.50	5240	4327	27500
20"	500	19.30	47.00	47.25	47.00	34.00	19.30	19.90	5820	4907	64250
24" x 20"	600 x 500	23.3 x 19.3	55.00	55.38	55.00	34.00	19.30	19.90	7165	5970	27400
22"	550	21.30	51.00	51.38	51.00	37.40	20.10	21.50	8356	7276	*
24"	600	23.30	55.00	55.38	55.00	40.60	22.40	23.40	10450	9255	96200
30" x 24"	750 x 600	29.0 x 23.3	65.00	65.50	65.00	40.60	22.40	23.40	12721	11326	47060
26"	650	25.00	57.00	57.50	57.00	43.00	24.40	25.00	12456	10935	101700
28"	700	27.00	61.00	61.50	61.00	46.00	27.20	26.20	14903	*	120200
30"	750	29.00	65.00	65.50	65.00	49.40	29.50	28.00	18475	17080	140300
36" x 30"	900 x 750	34.5 x 29.0	82.00	82.63	82.00	49.40	29.50	28.00	22884	20990	83500
32"	800	30.70	70.00	70.63	70.00	52.20	30.70	29.70	21473	*	157250
34"	850	32.80	76.00	76.63	76.00	55.30	32.10	30.70	25000	22134	178100
36"	900	34.50	82.00	82.63	82.00	57.70	33.10	32.10	29321	27427	195900



# ISV Series BT

## Dimensional Data Class 900

BOLTED OR WELDED DESIGN

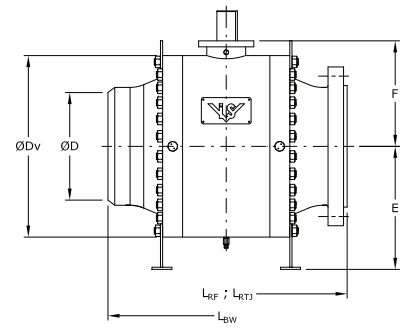

Class 900		Inches							Weight (lbs)		
NPS	DN	D	L RF	L RTJ	L BW	Dv	E	F	RF, RTJ	BW	Cv
2"	50	2.00	14.50	14.63	14.50	6.30	4.10	4.10	110	59	330
3" x 2"	80 x 50	3.0 x 2.0	15.00	15.13	15.00	6.30	4.10	4.10	117	86	185
3"	80	3.00	15.00	15.13	15.00	7.50	5.10	6.50	168	137	920
4" x 3"	100 x 80	4.0 x 3.0	18.00	18.13	18.00	7.50	5.10	6.50	214	177	530
4"	100	4.00	18.00	18.13	18.00	9.30	6.60	8.30	331	294	1800
6" x 4"	150 x 100	6.0 x 4.0	24.00	24.13	24.00	9.30	6.60	8.30	463	339	735
6"	150	6.00	24.00	24.13	24.00	12.60	8.30	10.20	809	685	4380
8" x 6"	200 x 150	8.0 x 6.0	29.00	29.13	29.00	12.60	8.30	10.20	985	776	2000
8"	200	8.00	29.00	29.13	29.00	16.50	10.50	11.60	1323	1114	8500
10" x 8"	250 x 200	10.0 x 8.0	33.00	33.13	33.00	16.50	10.50	11.60	1543	1191	4000
10"	250	10.00	33.00	33.13	33.00	20.30	13.00	13.60	2264	1912	14500
12" x 10"	300 x 250	12.0 x 10.0	38.00	38.13	38.00	20.30	13.00	13.60	2531	2046	7000
14" x 10"	350 x 250	12.8 x 10.0	40.50	40.88	40.50	20.30	13.00	13.60	2723	2127	*
12"	300	12.00	38.00	38.13	38.00	23.80	15.00	15.40	3435	2950	21400
14" x 12"	350 x 300	12.8 x 12.0	40.50	40.88	40.50	23.80	15.00	15.40	3622	3026	13100
16" x 12"	400 x 300	14.8 x 12.0	44.50	44.88	44.50	23.80	15.00	15.40	3832	2818	*
14"	350	12.80	40.50	40.88	40.50	25.20	14.60	15.70	3256	2660	26260
16" x 14"	400 x 350	14.8 x 12.8	44.50	44.88	44.50	25.20	14.60	15.70	3785	2771	14170
16"	400	14.80	44.50	44.88	44.50	28.10	17.10	17.30	4755	3741	35960
18" x 16"	450 x 400	16.7 x 14.8	48.00	48.50	48.00	28.10	17.10	17.30	5373	4359	19200
20" x 16"	500 x 400	18.6 x 14.8	52.00	52.50	52.00	28.10	17.10	17.30	6365	4998	*
18"	450	16.70	48.00	48.50	48.00	31.50	19.70	19.00	6305	5291	47700
20" x 18"	500 x 450	18.6 x 16.7	52.00	52.50	52.00	31.50	19.70	19.00	7187	5820	27000
20"	500	18.60	52.00	52.50	52.00	35.40	19.70	20.90	9303	7936	61250
24" x 20"	600 x 500	22.5 x 18.6	61.00	61.75	61.00	35.40	19.70	20.90	11905	9877	26300
24"	600	22.50	61.00	61.75	61.00	41.70	24.80	24.20	15102	13074	92100
30" x 24"	750 x 600	28.1 x 22.5	74.00	74.88	*	41.70	24.80	24.20	19290	15740	43600
26"	650	24.40	65.00	65.88	*	44.10	25.60	25.60	17725	*	93240
30"	750	28.10	74.00	74.88	*	51.20	30.70	28.50	26918	23368	131500
36"	900	33.70	90.00	91.13	*	60.20	35.40	33.30	43916	38161	148650

# ISV Series BT

## Dimensional Data Class 1500 and 2500

**BOLTED OR WELDED DESIGN**

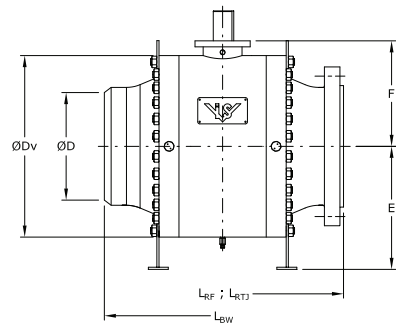

Class 1500		Inches							Weight (lbs)		
NPS	DN	D	L RF	L RTJ	L BW	Dv	E	F	RF, RTJ	BW	Cv
2"	50	2.00	14.50	14.63	14.50	6.30	4.10	4.10	117	14	330
3" x 2"	80 x 50	3.0 x 2.0	18.50	18.63	18.50	6.30	4.10	4.10	146	86	180
3"	80	3.00	18.50	18.63	18.50	7.50	5.10	6.50	216	156	820
4" x 3"	100 x 80	4.0 x 3.0	21.50	21.63	21.50	7.50	5.10	6.50	278	234	520
4"	100	4.00	21.50	21.63	21.50	9.60	6.60	8.50	441	397	1700
6" x 4"	150 x 100	5.7 x 4.0	27.75	28.00	27.75	9.60	6.60	8.50	639	484	730
6"	150	5.70	27.75	28.00	27.75	13.60	9.10	10.20	1069	914	4000
8" x 6"	200 x 150	7.6 x 5.7	32.75	33.13	32.75	13.60	9.10	10.20	1268	1004	1900
8"	200	7.60	32.75	33.13	32.75	17.70	11.20	11.80	1823	1559	7850
10" x 8"	250 x 200	9.5 x 7.6	39.00	39.38	39.00	17.70	11.20	11.80	2275	1846	3900
10"	250	9.50	39.00	39.38	39.00	21.90	13.80	14.40	3322	2893	12900
12" x 10"	300 x 250	11.4 x 9.5	44.50	45.13	44.50	21.90	13.80	14.40	3896	3345	6900
14" x 10"	350 x 250	12.5 x 9.5	49.50	50.25	49.50	21.90	13.80	14.40	4744	4049	*
12"	300	11.40	44.50	45.13	44.50	28.00	16.70	16.50	5009	4458	18000
14" x 12"	350 x 300	12.5 x 11.4	49.50	50.25	49.50	28.00	16.70	16.50	5593	4898	12600
16" x 12"	400 x 300	14.3 x 11.4	54.50	55.38	54.50	28.00	16.70	16.50	6188	5306	*
14"	350	12.50	49.50	50.25	49.50	30.30	16.90	17.30	6349	5654	23780
16" x 14"	400 x 350	14.3 x 12.5	54.50	55.38	54.50	30.30	16.90	17.30	7231	6349	13400
16"	400	14.30	54.50	55.38	54.50	33.50	19.70	18.90	9083	8201	32550
18" x 16"	450 x 400	16.0 x 14.3	60.50	61.38	*	33.50	19.70	18.90	10979	9767	18700
20" x 16"	500 x 400	18.0 x 14.3	65.50	66.38	*	33.50	19.70	18.90	11354	9722	*
18"	450	16.00	60.50	61.38	*	38.60	23.60	21.70	13801	12589	42500
20" x 18"	500 x 450	18.0 x 16.0	65.50	66.38	*	38.60	23.60	21.70	16623	14991	21100
20"	500	18.00	65.50	66.38	*	40.20	25.60	24.40	20106	18474	54800
24" x 20"	600 x 500	21.0 x 18.0	*	77.63	*	40.20	25.60	24.40	24141	21672	25100
24"	600	21.00	*	77.63	*	50.80	28.30	27.60	31570	29101	82350

Class 2500		Inches							Weight (lbs)		
NPS	DN	D	L RF	L RTJ	L BW	Dv	E	F	RF, RTJ	BW	Cv
2"	50	1.80	17.75	17.88	17.75	6.70	4.90	4.70	198	137	290
3" x 2"	80 x 50	2.5 x 1.8	22.75	23.00	22.75	6.70	4.90	4.70	348	216	160
3"	80	2.50	22.75	23.00	22.75	9.40	7.90	6.90	441	309	700
4" x 3"	100 x 80	3.6 x 2.5	26.50	26.88	26.50	9.40	7.90	6.90	595	395	420
4"	100	3.60	26.50	26.88	26.50	13.00	9.10	8.90	849	649	1200
6" x 4"	150 x 100	5.2 x 3.6	36.00	36.50	36.00	13.00	9.10	8.90	1140	632	580
6"	150	5.20	36.00	36.50	36.00	17.70	9.80	10.20	1715	1207	2550
8" x 6"	200 x 150	7.1 x 5.2	40.25	40.88	40.25	17.70	9.80	10.20	2421	1704	1600
8"	200	7.10	40.25	40.88	40.25	24.60	13.40	15.00	2981	2264	5350
10" x 8"	250 x 200	8.9 x 7.1	50.00	50.88	50.00	24.60	13.40	15.00	3675	2327	3200
10"	250	8.90	50.00	50.88	50.00	29.50	16.70	17.70	4711	3363	8500
12" x 10"	300 x 250	10.5 x 8.9	56.00	56.88	56.00	29.50	16.70	17.70	5659	3766	5400
12"	300	10.50	56.00	56.88	56.00	34.60	18.90	20.30	7202	5309	13000

# ISV Series BT

## Pressure Temperature Limits\*

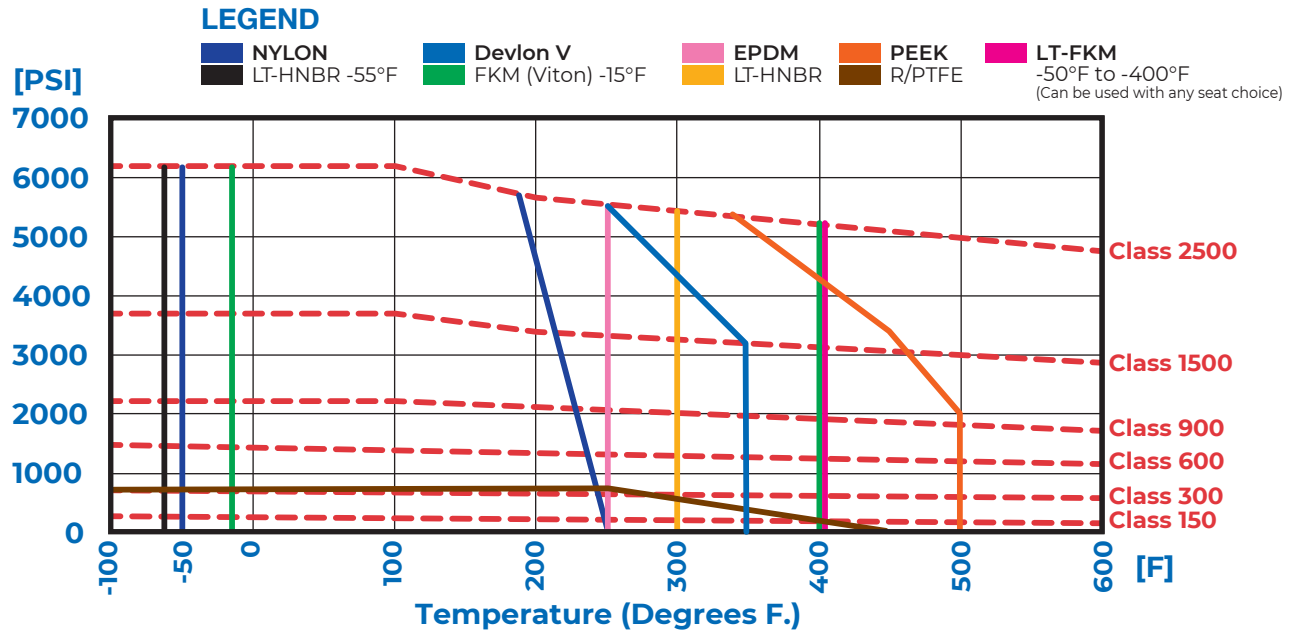

\*The Pressure/Temperature Limits of any valve are dependent upon the materials selected along with the seat/seal of choice.





# ISV Series BT3

## Trunnion Ball Valve Manual Gear Data



GEAR SIZING CHART							
VALVE SIZE		MODEL NUMBER					
NPS	CLASS	150	300	600	900	1500	2500
3" x 2"	2"					WGI-008	WGI-108
4" x 3"	3"			WGI-008		WGI-108	WGI-208
6" x 4"	4"	WGI-108	WGI-108	WGI-108	WGI-208	WGI-208	WGI-408
8" x 6"	6"	WGI-118	WGI-118	WGI-208	WGI-208	WGI-308	WGI-418
10" x 8"	8"	WGI-208	WGI-208	WGI-308	WGI-308	WGI-418	WGI-508
12" x 10"	10"	WGI-208	WGI-208	WGI-308	WGI-418	WGI-508	WGI-608
14" x 12"	12"	WGI-308	WGI-308	WGI-418	WGI-508	WGI-508	WGI-708
16" x 14"	14"	WGI-308	WGI-308	WGI-418	WGI-508	WGI-608	
18" x 16"	16"	WGI-418	WGI-418	WGI-508	WGI-608	WGI-608	
20" x 18"	18"	WGI-418	WGI-418	WGI-518			
24" x 20"	20"	WGI-508	WGI-508	WGI-608			
28" x 24"	24"	WGI-518	WGI-608	WGI-718	WGI-808		
36" x 30"	30"	WGI-718	WGI-728	WGI-1008			
42" x 36"	36"	WGI-908	WGI-1008	WGI-1108			

High quality manual worm gear operators are available for all trunnion mounted ball valves. Standard design features include:

- 2" Square Operating Nut
- Removable Handwheel w/2" Square Hub
- Crank Handle on Handwheels
- Locking Device
- Open/Closed Position Indicator
- ISO 5211 Mounting Bolt Pattern
- Adjustable Travel Stops
- Weather Proof Housing

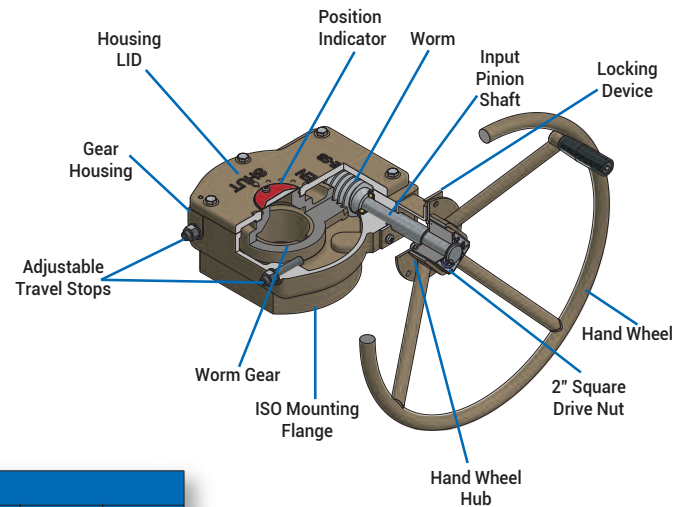
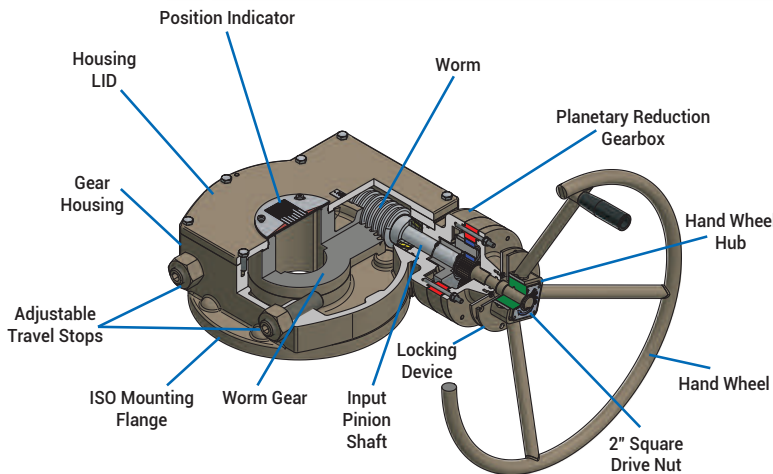

ISV GEAR DATA										
GEAR MODEL NO.	RATIO	EFFICIENCY	NO. OF TURNS (TO OPEN OR CLOSE)	TRAVEL	MAX. TORQUE (IN/LB)	ISO 5211 MOUNTING FLANGE	MAX. STEM OD (IN)	MAX. STEM LENGTH	HAND WHEEL SIZE (IN)	WEIGHT (LBS)
WGI-008	40:1	25%	10	90° ±5°	10621	F14	1.85	2.6	12	13
WGI-108	53:1	25%	13 1/4	90° ±5°	12922	F14	1.97	2.3	18	33
WGI-118	53:1	25%	13 1/4	90° ±5°	12922	F14	1.97	2.3	18	33
WGI-208	62:1	25%	15 1/2	90° ±5°	24694	F16	2.95	3.0	24	62
WGI-308	120.5:1	18.8%	30 1/5	90° ±5°	43193	F25	2.76	3.9	24	86
WGI-318	120.5:1	18.8%	30 1/5	90° ±5°	43193	F25	2.76	3.9	24	86
WGI-408	306:1	15%	76 1/2	90° ±5°	58487	F25	3.15	4.3	24	122
WGI-418	306:1	15%	76 1/2	90° ±5°	58487	F25	3.15	4.3	24	122
WGI-508	525:1	15%	131 1/2	90° ±5°	117099	F25	3.94	5.7	28	222
WGI-518	525:1	15%	131 1/2	90° ±5°	117099	F30	3.94	5.7	28	222
WGI-608	825:1	15%	206 1/4	90° ±5°	180412	F30	3.94	6.5	28	327
WGI-708	729:1	28.8%	182 1/4	90° ±5°	230126	F30	6.29	6.5	24	296
WGI-718	729:1	28.8%	182 1/4	90° ±5°	230126	F35	6.29	6.5	24	296
WGI-728	729:1	28.8%	182 1/4	90° ±5°	230126	F35	6.29	6.5	36	296
WGI-808	720:1	36.9%	182	90° ±5°	425733	F40	6.18	6.3	36	490
WGI-908	870:1	28.8%	217 1/2	90° ±5°	283224	F40	5.52	6.93	28	428
WGI-1008	1698:1	15%	424 1/2	90° ±5°	442537	F40	5.52	8	24	816
WGI-1108	2459:1	15%	614 3/4	90° ±5°	708060	F40	5.91	9.33	28	1257

# ISV Series BT

## Stem Extensions for Buried Service: Typical Configurations

ISV can provide in-house customization for buried service. Customer specified extension length and design options are available upon request.

STEM EXTENSION AVAILABLE ON VALVE SIZES 2" - 42"

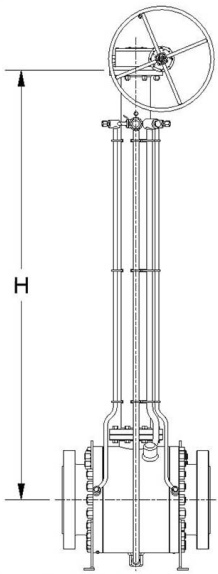

H=Length of the Stem Extension from center line of valve to top of gearbox/actuator mounting flange.

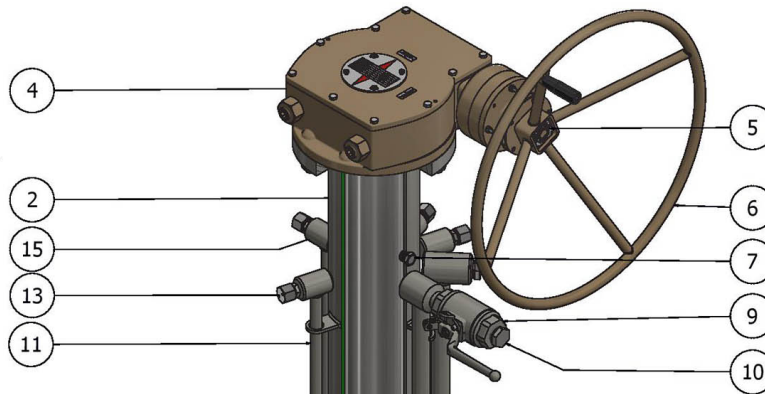

TYPICAL PARTS LIST		
ITEM	DESCRIPTION	REMARK
1	TRUNNION BALL VALVE	
2	STEM EXTENSION	
3	INNER EXTENSION SHAFT	
4	ISV GEAR OPERATOR	FOR VALVE 6" AND LARGER
5	SQUARE OPERATING NUT	
6	HANDWHEEL	
7	WEATHERPROOF BREATHER PLUG	
8	DRAIN LINE	
9	DRAIN VALVE	
10	NPT PLUG	
11	SEAT LUBE LINES	SEPERATE LINES STANDARD
12	INTERNAL CHECK VALVE	REMOVABLE
13	GIANT BUTTON HEAD GREASE PORT	
14	VENT LINE	OPTIONAL
15	STEM LUBE LINE	OPTIONAL
16	STEM LUBE CHECK VALVE	OPTIONAL (NOT SHOWN)
17	FITTING	WELDED IS STANDARD

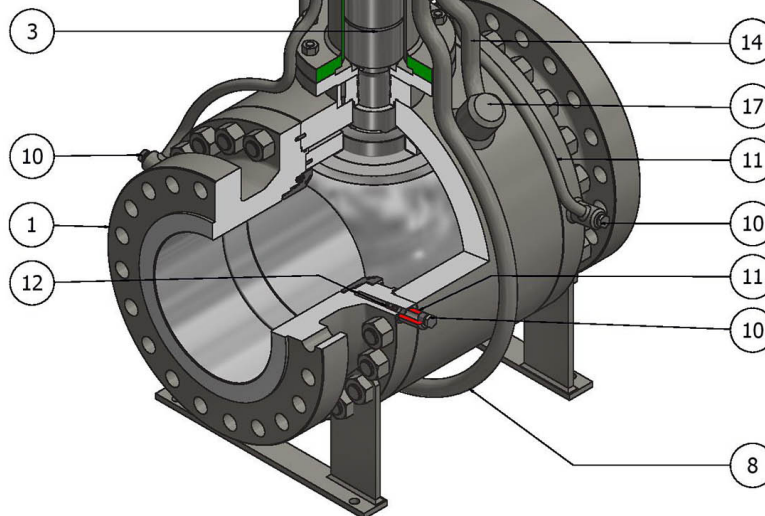

# ISV Series BT

## Pinion Shaft Extensions for Buried Service: Typical Configuration

ISV can provide in-house customization for buried service. Customer specified extension length and design options are available upon request.

PINION  
SHAFT  
EXTENSION  
AVAILABLE ON  
VALVE SIZES  
2" - 42"

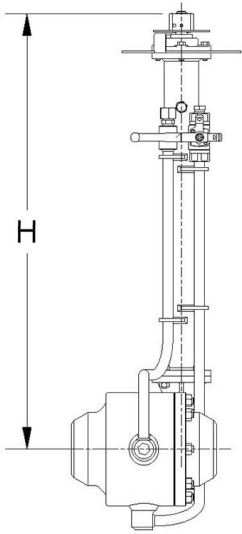

H = Center Line of valve to  
Top of 2" Square Operating Nut

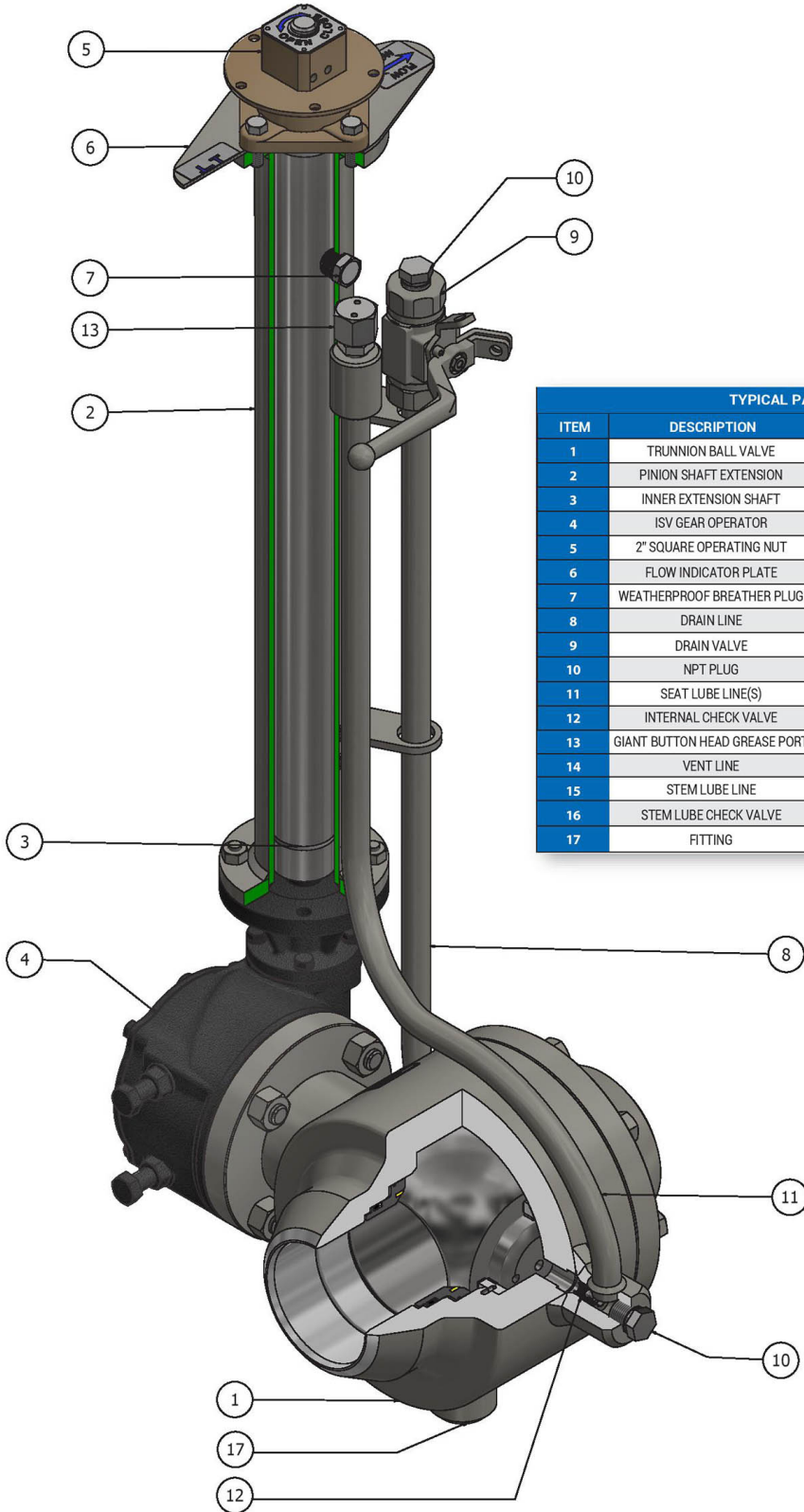

TYPICAL PARTS LIST		
ITEM	DESCRIPTION	REMARK
1	TRUNNION BALL VALVE	
2	PINION SHAFT EXTENSION	
3	INNER EXTENSION SHAFT	
4	ISV GEAR OPERATOR	FOR VALVE 6" AND LARGER
5	2" SQUARE OPERATING NUT	WITH LOCKING DEVICE
6	FLOW INDICATOR PLATE	
7	WEATHERPROOF BREATHER PLUG	
8	DRAIN LINE	
9	DRAIN VALVE	
10	NPT PLUG	
11	SEAT LUBE LINE(S)	SEPERATE LINES STANDARD
12	INTERNAL CHECK VALVE	REMOVABLE
13	GIANT BUTTON HEAD GREASE PORT	
14	VENT LINE	OPTIONAL (NOT SHOWN)
15	STEM LUBE LINE	OPTIONAL (NOT SHOWN)
16	STEM LUBE CHECK VALVE	OPTIONAL (NOT SHOWN)
17	FITTING	WELDED IS STANDARD





# ISV Series BT

## Differential Thermal Relief (DTR) System

Designed to relieve excessive trapped body cavity pressure resulting from thermal media expansion.

DTR systems are needed on valves with DIB-1 seat configurations particularly when used in fluid or liquid service. When a DIB-1 valve is in closed position the valve cavity pressure can rise above the MOP of the valve, due to the thermal expansion of the media. Thermal expansion effects are more severe in liquid service.

DTR systems utilize a check valve with a set differential pressure of typically 25 psi as a pressure relief mechanism. The DTR system will automatically relieve cavity pressure when the valve cavity pressure exceeds the pressure of the pipeline, where the DTR system is tied in to, by more than the differential value of the check valve.

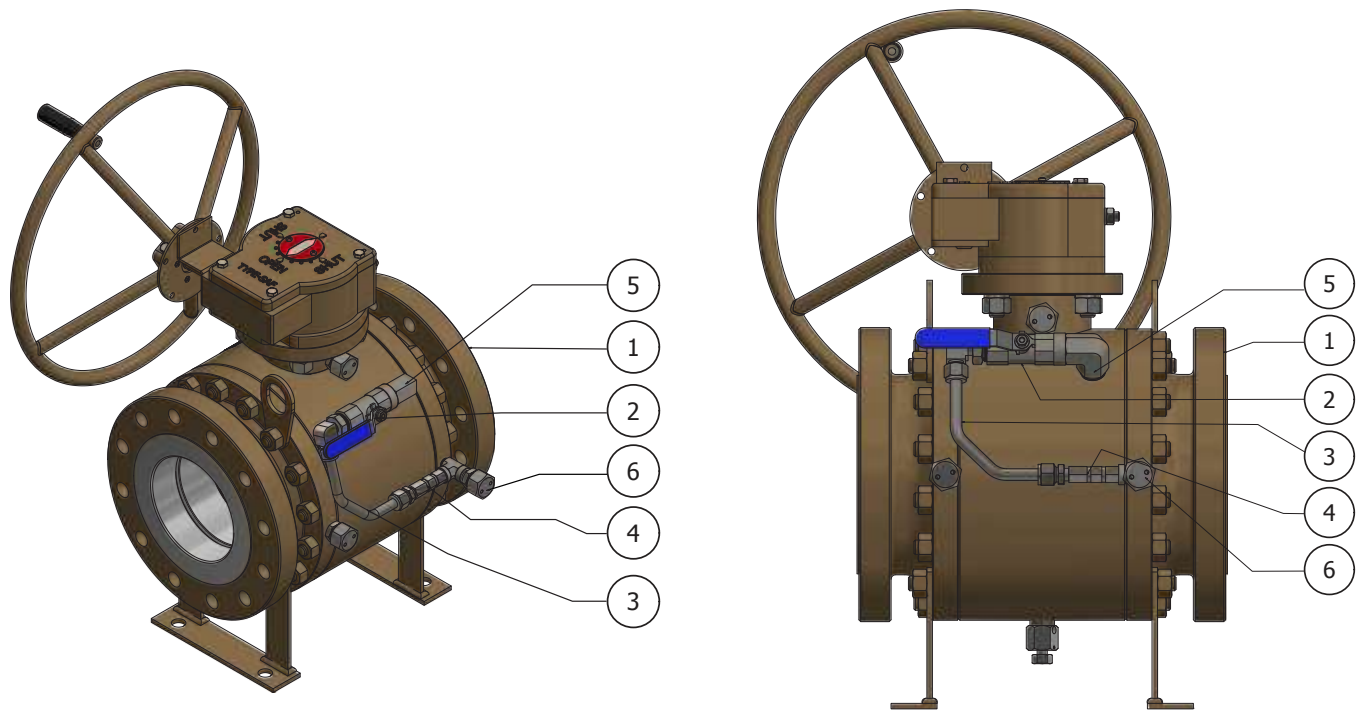

DTR PARTS LIST		
ITEM	DESCRIPTION	REMARKS
1	DIB-1 TRUNNION BALL VALVE	
2	DTR SYTEM BALL VALVE	STANDARD
	NEEDLE VALVE	OPTIONAL
3	DTR TUBING	1/2" MINIMUM
4	DTR CHECK VALVE/RELIEF	5-25 PSIG STANDARD
5	BODY CAVITY FITTING	
6	PIPELINE PORT	EMERGENCY GREASE INJECTION FITTING

Items 2, 3, 4 and 5 are of 316SS materials.

# ISV Series BT

## Ball Valves for Special Applications: Cryogenic and Metal Seated

### Metal Seated ISV Series BT4E/BT9E:

ISV's Metal seated ball valves are designed for the most severe applications where high temperature and or abrasive factors influence the process. They are ideally suited for the mineral and mining processing industries slurry, sandy oil and gas applications.

Available in both floating and trunnion ball valve designs.

The ball and the metal seat contact surfaces are coated with wear resistant materials by HVOF (High Velocity Oxygen Fuel) thermal coating process, which provides a strong metal bonding with minimal impact to the metal deformation.

- -50°F to 932°F (higher on application)
- Seat Leakage Testing ANSI/FCI 70-2 Class V. Class VI is available upon request.
- Metal seat hard face coatings are available in Stellite®, Tungsten Carbide or Chrome Carbide options.
- Seats are lapped to the ball with extremely tight tolerances providing very tight shut-off. Other seat materials are available on request.



### Cryogenic ISV Series BT7E:

ISV's Cryogenic three piece ball valves are specifically designed for LNG production, transportation, storage and other low temperature applications. Extended stems with gas columns and bonnets are designed to position the stem packing above the cryogenic process, which then provides a column of warmer vapor that insulates the stem seal from the effects of the low temperatures.

- Designs are in accordance with ASME 16.34, API 6D, API 608, and MSS SP 134.
- 1-PC Extended Stem, Our stem is made of one solid component piece extended to the valves ball. The packing is insulated and there is no leak path in the extension.
- PCTFE (KEL-F®) Seats are standard
- Soft and Metal seated
- Long cycle life
- Low torques.
- Vented Ball Standard
- Live-Loaded Packing and Anti-Static Standard

ISV cryogenic valves are not limited to Ball valves. We also offer Gate and Globe valves for cryogenic applications.



# INTERNATIONAL STANDARD VALVE



ISV

TM

**INTERNATIONAL STANDARD VALVE, INC.**

**13124 TRINITY DRIVE ▼ STAFFORD, TEXAS 77477**

**713-983-7600 ▼ SALES@ISVALVE.COM**

**WWW.ISVALVE.COM**



is a registered trademark of International Standard Valve, Inc.

©2021 International Standard Valve, Inc. (ISV) All rights reserved. The contents of this publication are presented for information purposes only and they are not to be construed as warranties or guarantees, express or implied, regarding the products or services described herein or their use or applicability. International Standard Valve, Inc. (ISV) reserves the right to modify the designs or specifications of such products at any time without notice. International Standard Valve, Inc. (ISV) does not assume responsibility for the selection, use or maintenance of any product. Responsibility for proper selection, use and maintenance of any International Standard Valve, Inc. (ISV) product remains solely with the purchaser and end-user.

Viton is a registered trademark of Chemours, Delrin is a registered trademark of DuPont, PEEK is a trademark of Victrex Plc., Devlon is a registered trademark of James Walker, Monel is a registered trademark of Special Metals Corp., Inconel is a registered trademark of Special Metals Corp., TFM is a trademark of 3M/Dyneon.