



INTERNATIONAL STANDARD VALVE INC.

ISV

ISV TRUNNION BALL VALVES FOR THE GAS INDUSTRY



PIPELINE TRANSMISSION,
MID-STREAM,
NATURAL GAS DISTRIBUTION

ISV's welded body trunnion, Series BT3GU, is our domestically manufactured welded body trunnion available in flanged or butt weld end connections, ideal for buried service with many inherently superior design features. We of course manufacture conventional flanged end valves as well.



ISV series BT3EU is our split body side entry design offered from 2"-42" ANSI Class 150-2500. The BT3EU offers many design features as well that set us apart from our competitors.



ISV's in house automatic welding machine, capable of welding up to 42" valves.

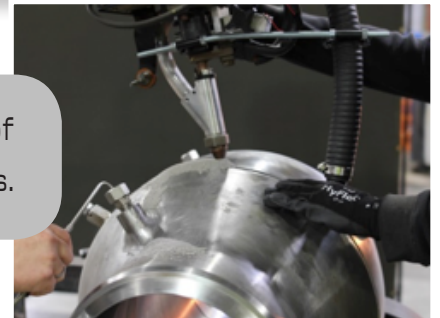

The largest hydro test stand gives us the capability of assembling and testing up through 42" valves.

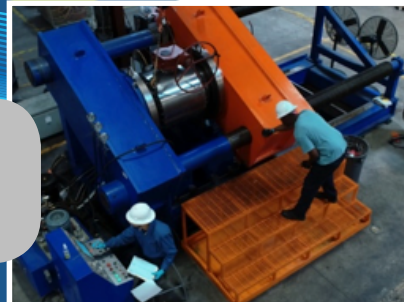

isvalve.com

713-983-7600

13124 Trinity Drive • Stafford, TX 77477

713-983-7602

Sales@isvalve.com



INTERNATIONAL STANDARD VALVE INC.

ISV



ISV's trunnion small valves in stock ready for shipment!



ISV's trunnion valves with high lead extensions. ISV can tailor the design to each end user's specification and provide the special coatings usually associated with buried service.



ISV can provide high head extensions and also pinion shaft extensions for buried service.

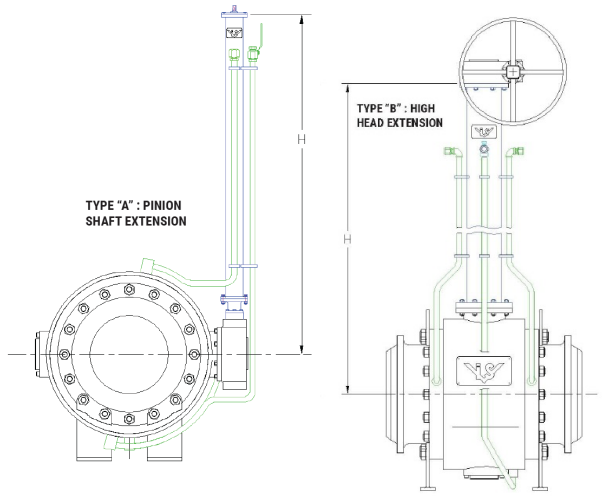

30" ANSI 150 ISV's trunnion with an actuator as specified by our customer.



isvalve.com

713-983-7600

13124 Trinity Drive • Stafford, TX 77477

713-983-7602

Sales@isvalve.com