



ISV Series BF1BU

Industrial Floating Ball Valve Flanged Ends, *Split Body* Adjustable Stem Packing Design

For Oil & Gas Production, Chemical, Petro-Chemical & Industrial applications



Sizes
1/2" through 8"

Pressure Classes
150, 300 & 600

API 608 Design
ASME B16.34
Code Compliant

DESIGN FEATURES

- 2 piece bolted split body design*
- Adjustable stem packing*
- WCB, LCC, CF8M & alloy material options*
- Lockable Lever or Gear operator*
- Fire safe tested to API 607*
- Meets NACE MR01-75 / MR0103*

The valves described in this brochure are **designed, assembled and tested in Stafford, Texas USA.**
Contains domestic and/or internationally produced components.

QUALITY MANAGEMENT SYSTEM
CERTIFIED BY DNV
ISO 9001:2008



Series BF1BU: Design, Assembled & Testing in Stafford

ISV ball valves are manufactured in accordance with applicable industry standards. Final assembly & testing of the valves represented in this brochure is performed in Stafford, Texas USA by well trained and qualified personnel, in a safe & ecologically responsible environment.

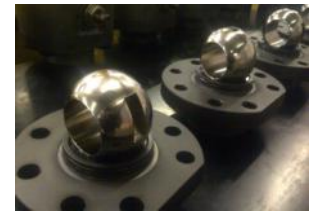

Specifying ISV Series BF1BU Floating Ball Valves

Example: ISV figure number BF1BU-F015-2436-RF-CG-NFL

Describes an ASME class 150, 2 piece bolted split-body design, full port, floating ball valve, raised face flange ends, LCC body with all valve materials suitable for (minus) -50 degrees F. service, 316SS trim, TFM 4215 (R-PTFE) seat inserts, graphite stem packing & gaskets, meets NACE MR01-75 & MR0103, is fire safe tested to API 607, lever operated. Assembled & tested in the USA.

B	F	1	BU	-	F	0	1	5	-	2	4	3	6	R	F	-	C	G	-	N	F	L	-		
1		2	3		4	5				6		7		8			9	10		11		12		13	

1 Valve Type		2 Service / Design style		3 Body Design		4 Bore		5 Pressure Rating		6 Body Material		7 Trim Material	
Code	Type	Code	Design style	Code	Body style	Code	Port	Code	Rating	Code	Material	Code	Material
BF	Ball Valve, Floating	1	Adjustable Stem Packing	AU	1 pc Uni-Body	R	Red.	015	Class 150	12	WCB (-20 Deg. F. Service)	30	* Stainless Steel
		3	O Ring Stem Packing	BU	2 pc Split Body, Bolted	F	Full	030	Class 300	24	LCC (-50 Deg. F. Service)	34	* 304SS / CF8
		4	Metal Seated	EU	3 pc Bolted Body			060	Class 600	34	CF8 Δ	36	* 316SS / CF8M
		7	Cryogenic Service	KU	Tandem			090	Class 900	36	CF8M Δ	51	F51
				LU	Double Ball—Single Body			150	Class 1500	11	A105N (-20 Deg.F. Service)	60	Inconel 625
								250	Class 2500	22	LF2 (-50 Deg.F. Service)	71	Monel
				**	"U" indicates USA production							61	410SS

8 End Connections		9 Seat Material		10 Stem Packing & Body Seal		11 Features		12 Operator		13 Modifier Code	
Code	Ends	Code	Material	Code	Material	Code	Description	Code	Description	Code	Description
RF	RF Flanged	R	RPTFE (glass filled PTFE)	G	Graphite	NF	NACE Compliant, Fire Safe Tested	L	Locking Lever	XXX	Special Configurations such as exotic materials, specific seat or sealing compounds. Consult ISV representative for modifier code identification.
RJ	RTJ Flanged	T	PTFE (virgin PTFE)	T	PTFE			B	Bare Stem		
WW	WE X WE	C	R-TFM 4215 (25% carbon filled modified PTFE)	M	TFM	NW	NACE Compliant, Fire Safe Design	S	Spring Return Lever		
WF	WE X RF	M	TFM 1600 (modified virgin PTFE)	K	PCTFE			G	Manual Gear		
WJ	WE X RTJ	P	PEEK	R	R-PTFE	WF	Without NACE, Fire Safe	A	Actuated		
		K	PCTFE	C	R-TFM			C	Chain Wheel		
		1	Tungsten Carbide Coated			WW	Without NACE, Fire Safe Design	O	Oval Hand Wheel		
		2	Chromium Carbide Coated								

* Ball and/or stem may be furnished as duplex SS or XM-19 for improved strength and durability.

Δ Forged equivalent material such as F304SS or F316SS may be furnished on 2" and smaller special order products.



DESIGN & PRODUCTION FEATURES

- API 608 & ASME B16.34 code compliant
- Adjustable stem packing
- Fire safe tested to API 607 6th Edition
- Lockable lever or gear is standard
- Meets NACE MR01-75 / MR0103
- ISO 5211 actuator mounting pad
- Optional lockable oval handles are available

DESIGN STANDARDS

Basic Design		ASME B16.34, API 608
Pressure test		API 598
Face to Face Dimension		ASME B16.10
Ends	Flanged	ASME B16.5

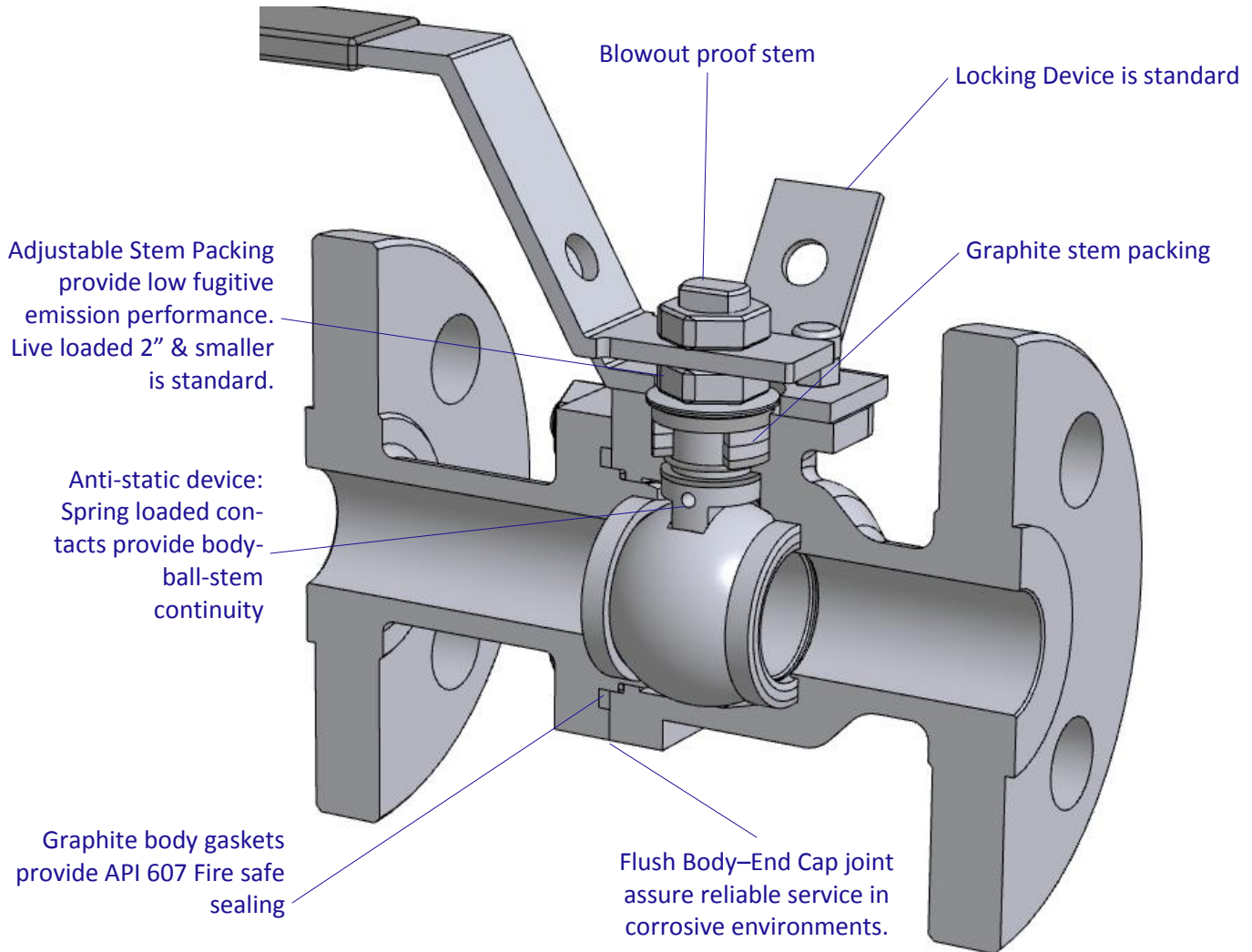

1" valve size is shown





ISV Series BF1BU - Standard Material Options

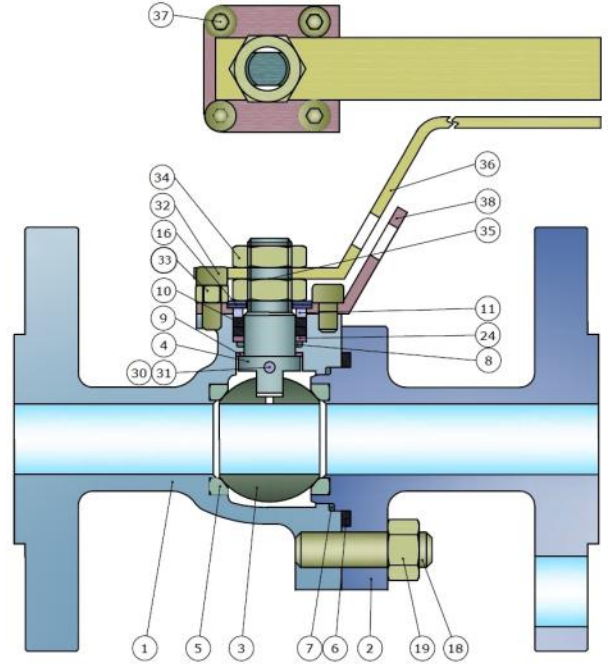

1/2" - 1" body style

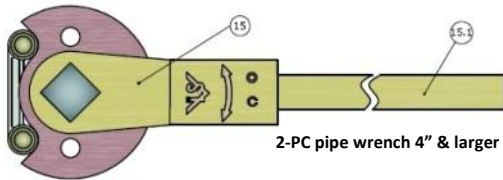

2-PC pipe wrench 4" & larger

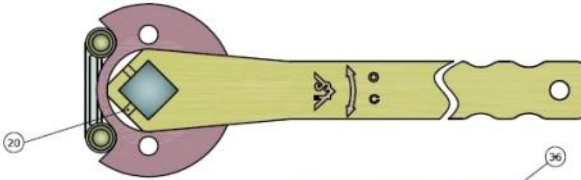

1-PC lever 3" & smaller

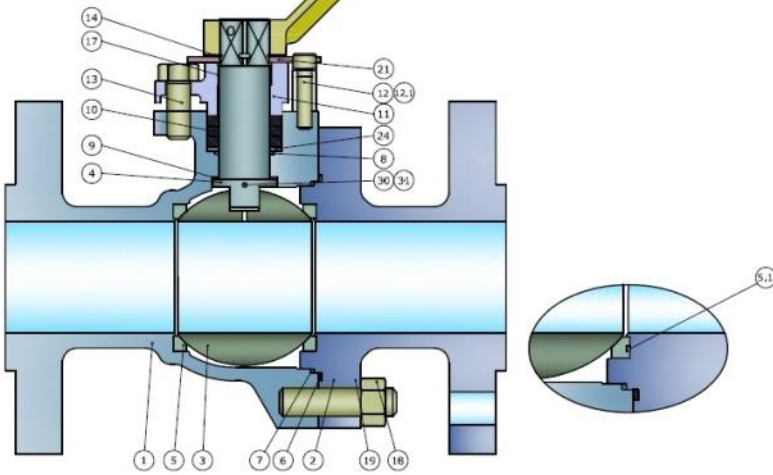

1-1/2" - 8" body style, lever operated

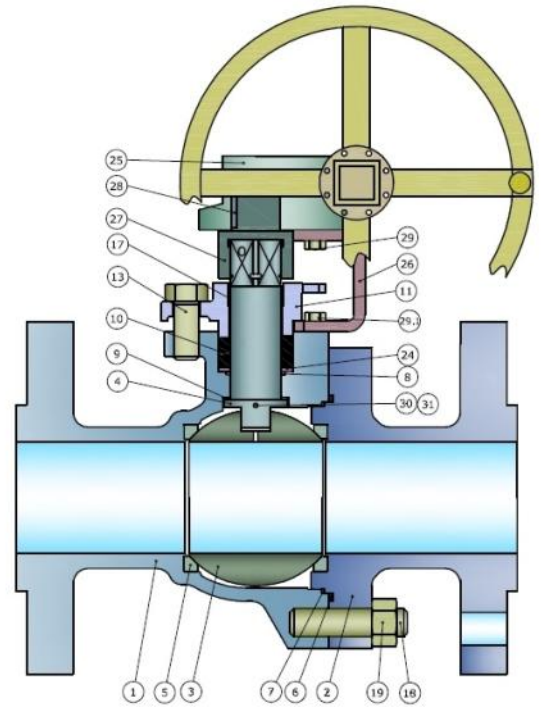

1-1/2" - 8" body style, gear operated



ISV Series BF1BU - Standard Material Options

No.	PART NAME	-20 DEG. F. SERVICE	-50 DEG. F. SERVICE	CORROSIVE SERVICE
1	BODY	ASTM A216 WCB	ASTM A352 LCC	ASTM A351 CF8M
2	END CAP	ASTM A216 WCB	ASTM A352 LCC	ASTM A351 CF8M
3	BALL	ASTM A182 F316	ASTM A182 F316	ASTM A182 F316
4	STEM	All sizes class 150 & 300	XM-19	XM-19
		.5" - 1" class 600	F53	F53
		1.5" - 4" class 600	XM-19	XM-19
5	SEAT	All sizes class 150 & 300	TFM 4215 (25% carbon filled PTFE)	TFM 4215 (25% carbon filled PTFE)
		.5" - 1" class 600	TFM 4215 (25% carbon filled PTFE)	TFM 4215 (25% carbon filled PTFE)
		1.5" - 4" class 600	PEEK	PEEK
5.1	O-RING: PEEK SEAT	PTFE	PTFE	PTFE
6	BODY-END CAP GASKET	GRAPHITE+316 SS	GRAPHITE+316 SS	GRAPHITE+316 SS
7	O-RING: BODY	PTFE	PTFE	PTFE
8	O-RING: STEM	PTFE	PTFE	PTFE
9	STEM THRUST WASHER	PTFE	PTFE	PTFE
10	STEM PACKING	GRAPHITE	GRAPHITE	GRAPHITE
11	GLAND	ASTM A216 WCB	ASTM A352 LCC	ASTM A351 CF8M
12	STOP	ASTM A216 WCB	ASTM A216 WCB	ASTM A351 CF8
12.1	STOP SCREW	ANSI 1035	ANSI 1035	304SS
12.2	CAP SCREW	ANSI 1035	ANSI 1035	304SS
13	CAP SCREW: GLAND	ASTM A193 B7M + zinc	ASTM A320 L7M + zinc	ASTM A193 B8M
14	SNAP RING	ANSI 6150	ANSI 6150	301SS
15	LEVER ADAPTOR	ASTM A216 WCB	ASTM A216 WCB	ASTM A216 WCB
15.1	PIPE HANDLE	AISI 1020	AISI 1020	AISI 1020
16	BELLEVILLE SPRING WASHER	301 SS	301 SS	301 SS
17	BEARING: STEM	PTFE	PTFE	PTFE
18	BODY-END CAP STUD	ASTM A193 B7M + zinc	ASTM A320 L7M + zinc	ASTM A193 B8M
19	BODY-END CAP NUT	ASTM A194 2HM + zinc	ASTM A194 7M + zinc	ASTM A194 8M
20	CAP SCREW: LEVER	304 SS	304 SS	304 SS
21	STOP PLATE	AISI 410 SS	AISI 410 SS	AISI 410 SS
22	NAME PLATE	304 SS	304 SS	304 SS
23	RIVET	304 SS	304 SS	304 SS
24	PACKING WASHER	ASTM A276 316	ASTM A276 316	ASTM A276 316
25	GEAR	CS	CS	CS
26	BRACKET	CS	CS	CS
27	COUPLING SHAFT	AISI 1045	AISI 1045	AISI 1045
28	KEY: COUPLING SHAFT	AISI 1045	AISI 1045	AISI 1045
29	CAP SCREW: BRACKET UPPER	AISI 1035	AISI 1035	304 SS
29.1	CAP SCREW: BRACKET LOWER	AISI 1035	AISI 1035	304 SS
30	ANTI-STATIC SPRING	AISI 316 SS	AISI 316 SS	AISI 316 SS
31	ANTI-STATIC BALL	AISI 316 SS	AISI 316 SS	AISI 316 SS
32	STOP SCREW	304 SS	304 SS	304 SS
33	STOP NUT	304 SS	304 SS	304 SS
34	STEM NUT	304 SS	304 SS	304 SS
35	LOCK WASHER	410 SS	410 SS	410 SS
36	LEVER	410 SS	410 SS	410 SS
37	CAP SCREW	304 SS	304 SS	304 SS
38	LOCK PLATE	410 SS	410 SS	410 SS

Other materials are available upon request.



ISV Series BF1BU - Standard Dimensions

DIMENSIONAL STANDARDS

Valve Design	API 608 /ASME B16.34
Flanged End Connection	ASME B16.5
End to End	ASME B16.10

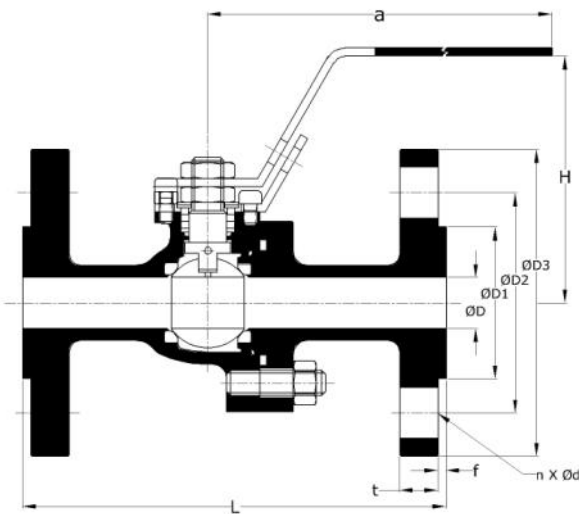
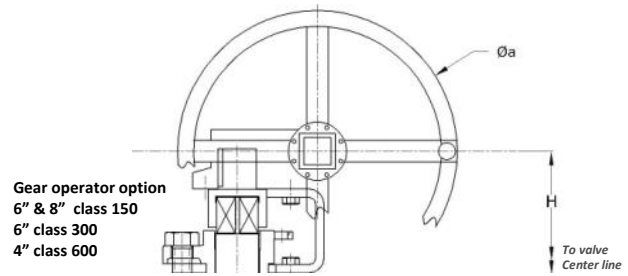
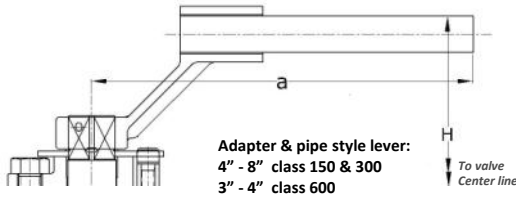

Typical 1/2" - 1" body style

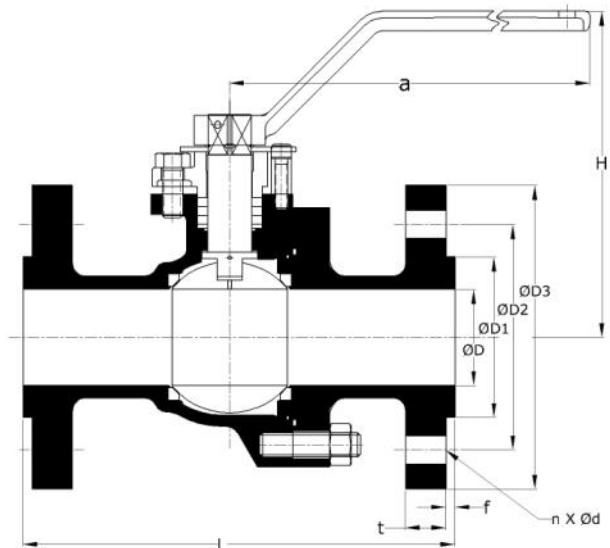

Typical 1-1/2" - 8" body style

INCHES

	Valve Size	L	ØD	ØD1	ØD2	ØD3	f	t	a	Øa	H Lever	H Gear	Cv	WT (LBS) [lever/gear]	n= number of bolt holes X Ød
CLASS 150	1/2"	4.29	0.51	1.37	2.37	3.54	0.08	0.31	6.30	-	3.48	-	23.6	4	4 X Ø0.63
	3/4"	4.61	0.75	1.69	2.75	3.93	0.08	0.35	6.30	-	3.64	-	53.2	5	4 X Ø0.63
	1"	5.00	1.00	2.00	3.13	4.33	0.08	0.38	7.87	-	4.17	-	94.6	7	4 X Ø0.63
	1 1/2"	6.50	1.50	2.87	3.87	4.92	0.08	0.50	9.84	-	6.14	-	237	13	4 X Ø0.63
	2"	7.00	2.00	3.63	4.75	5.91	0.08	0.56	11.02	-	7.06	-	422	22	4 X Ø0.75
	3"	8.00	3.00	5.00	6.00	7.50	0.08	0.69	12.60	-	8.28	-	948	45	4 X Ø0.75
	4"	9.00	4.00	6.19	7.50	9.06	0.08	0.88	15.75	-	10.08	-	2200	80	8 X Ø0.75
	6"	15.51	6.00	8.50	9.50	11.02	0.08	0.94	31.50	13.8	11.00	11.50	4700	[175 / 205]	8 X Ø0.87
8"	18.00	8.00	10.63	11.75	13.58	0.08	1.06	53.15	18.0	13.50	14.50	9400	[345 / 375]	8 X Ø0.87	

	Valve Size	L	ØD	ØD1	ØD2	ØD3	f	t	a	Øa	H Lever	H Gear	Cv	WT (LBS) [lever/gear]	n= number of bolt holes X Ød
CLASS 300	1/2"	5.51	0.51	1.37	2.63	3.74	0.08	0.50	6.30	-	3.48	-	23.6	5	4 X Ø0.63
	3/4"	5.98	0.75	1.69	3.25	4.53	0.08	0.56	6.30	-	3.64	-	53.2	8	4 X Ø0.75
	1"	6.50	1.00	2.00	3.50	4.92	0.08	0.63	7.87	-	4.17	-	94.6	10	4 X Ø0.75
	1 1/2"	7.48	1.50	2.87	4.50	6.10	0.08	0.75	9.84	-	6.14	-	237	22	4 X Ø0.87
	2"	8.50	2.00	3.63	5.00	6.50	0.08	0.81	11.00	-	7.06	-	422	29	8 X Ø0.75
	3"	11.10	3.00	5.00	6.63	8.27	0.08	1.06	12.60	-	8.28	-	948	63	8 X Ø0.87
	4"	12.00	4.00	6.19	7.87	10.04	0.08	1.19	23.62	-	9.92	-	2200	110	8 X Ø0.87
6"	15.87	6.00	8.50	10.63	12.60	0.08	1.38	39.37	13.8	11.00	11.50	4700	[232 / 262]	12 X Ø0.87	

	Valve Size	L	ØD	ØD1	ØD2	ØD3	f	t	a	Øa	H Lever	H Gear	Cv	WT (LBS) [lever/gear]	n= number of bolt holes X Ød
CLASS 600	1/2"	6.50	0.51	1.37	2.63	3.74	0.28	0.56	6.30	-	3.48	-	23.6	6	4 X Ø0.63
	3/4"	7.48	0.75	1.69	3.25	4.53	0.28	0.63	6.30	-	3.64	-	53.2	9	4 X Ø0.75
	1"	8.50	1.00	2.00	3.50	4.92	0.28	0.69	7.87	-	4.17	-	94.6	13	4 X Ø0.75
	1 1/2"	9.49	1.50	2.87	5.00	6.10	0.28	0.88	9.84	-	6.18	-	237	29	4 X Ø0.87
	2"	11.50	2.00	3.63	5.00	6.50	0.28	1.00	12.60	-	7.72	-	422	44	8 X Ø0.75
	3"	14.00	3.00	5.00	6.63	8.30	0.28	1.25	27.60	-	9.75	-	948	95	8 X Ø0.88
	4"	17.00	4.00	6.19	8.50	10.83	0.28	1.50	39.37	13.8	9.75	10.50	2200	[180 / 210]	8 X Ø1.0



ISV Series BF1BU - Pressure-Temperature Ratings

The pressure temperature ratings for the **BF1BU** Series flanged end floating ball valves are determined by the ASME B16.34 pressure class, valve body material grades and the limits of the seat and seals materials.

The following pressure-temperature charts indicate the service range of standard ISV seat & seals material options.

For P-T ratings of other materials, contact your ISV customer service representative.

1/2" - 1" CLASS 150 - 600, FULL PORT

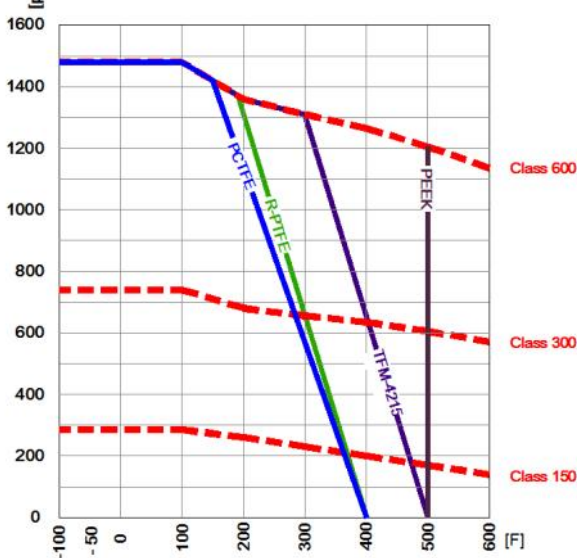

1-1/2" - 2" CLASS 150 - 600, FULL PORT

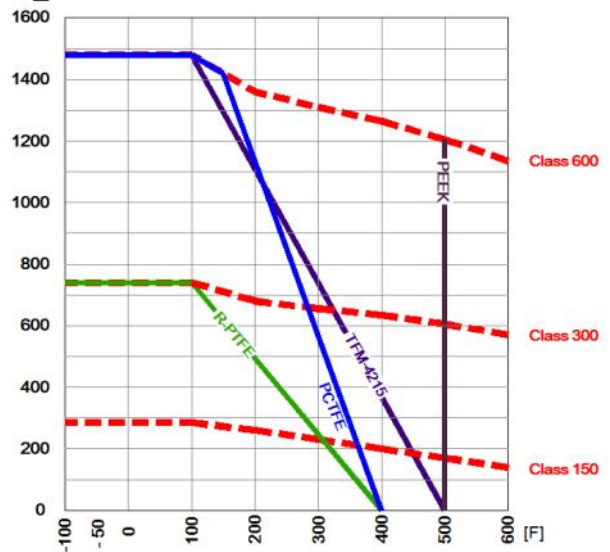

3" & 4" CLASS 150 - 600, FULL PORT

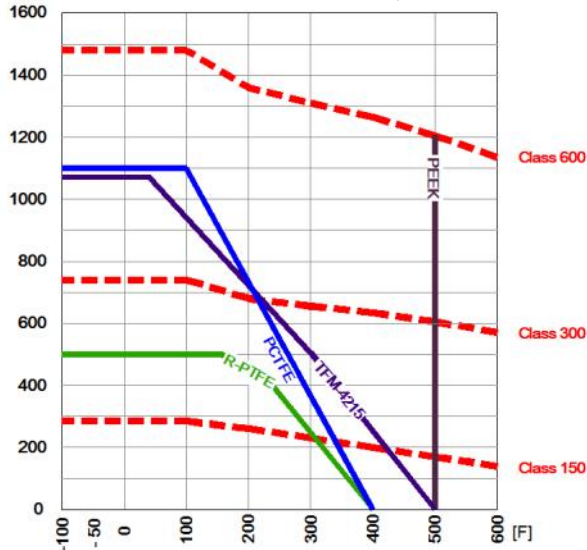

6" - 10" CLASS 150 & 300, FULL PORT

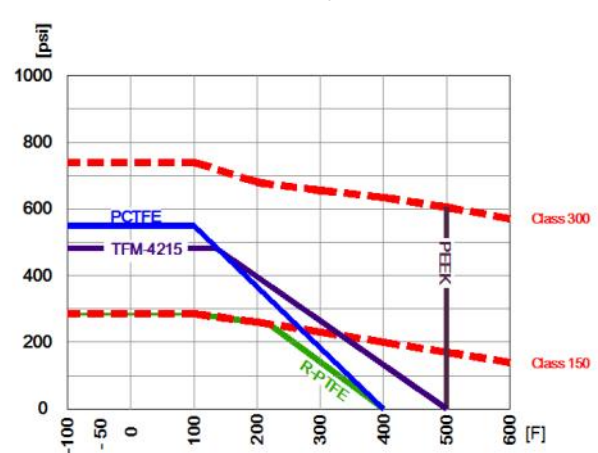

--- WCB body material is shown in the charts above.
(Lower temp. limit for WCB material is -20 deg. F.)

LOW TEMPERATURE LIMITS			
BODY MATERIAL	ASTM GRADE	°F	°C
	WCB	MINUS 20	MINUS 28.89
	LCC	MINUS 50	MINUS 45.56
CF8M	MINUS 320	MINUS 195.56	



Other ISV valves produced in Stafford



3PC TRUNNION BALL VALVES



**THREADED, SOCKETWELD & FLANGED
3PC FLOATING BALL VALVES**

Distributed by:

**The valves described in this brochure are designed, assembled and tested in Stafford, Texas USA.
Contains domestic and/or international components.**

Devlon is a registered trademark of James Walker Devol company, PEEK is a trademark of Victrex plc., TFM is a trademark of 3M Company,



is a registered trademark of **International Standard Valve, Inc.**, 10749 Cash Road, Stafford, Texas 77477
Phone: 713-983-7600

www.isvalve.com

sales@isvalve.com

Bulletin No. SB1400.0 Issue 03/2016

