



ISV Series No. BF2E-F

3 Piece Bolted Body Full Port Floating Ball Valve

ASME B16.34 Code Compliant

Threaded, Socket Weld and Butt-weld End Connection options

DESIGN STANDARDS		
Basic Design	ASME B16.34, API 608	
Pressure test	API 598	
Ends	Threaded	ASME B16.11, B1.20.1
	Socket weld	ASME B16.11
	Butt-weld	ASME B16.25



DESIGN & PRODUCTION FEATURES

3 Piece bolted body design simplifies maintenance activities long after installation.

- Adjustable live loaded stem packing plus reliable o-ring stem seal
- Removable-Replaceable body section
- Enclosed body-cap bolting
- Two size ISO actuator mounting pad
- Threaded, Socket weld or butt-weld ends available
- Durable TFM 4215 (reinforced PTFE) seats: standard
- 316SS ball & stem is standard
- Locking Lever is standard
- ISO actuator mounting pad is standard
- Optional locking oval handles are available
- Meets ASME B16.34 & API 608
- Pressure tested to API 598
- Fire safe tested to API 607 5th Edition
- Meets NACE

PRESSURE RATING: WCB and CF8M
2000 PSIG @ 100°F W.O.G.—1/2" - 1 1/4"
1500 PSIG @ 100°F W.O.G.—1 1/2" - 2"
Water, Oil or Gas

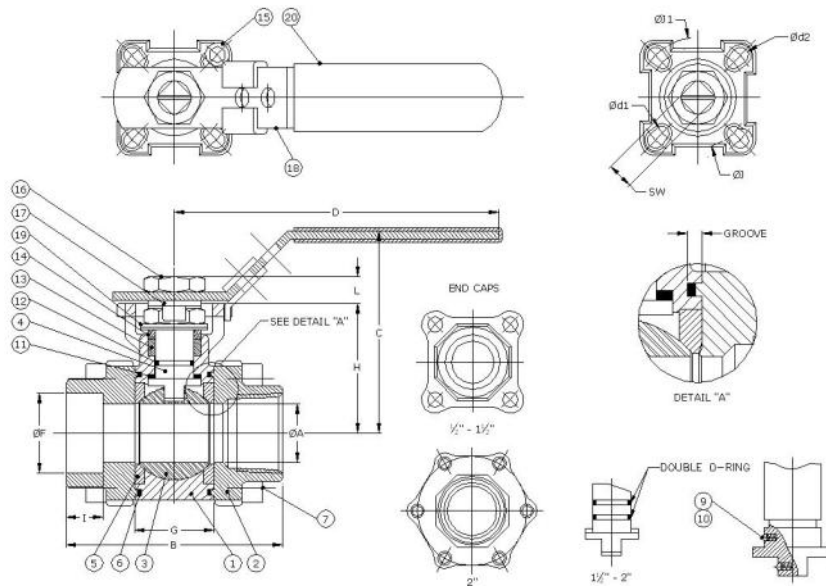

Socket weld end modification note: Threaded end connections that are modified to socket weld end connections will result in reduced pressure rating of the valve due to reduction of end cap wall thickness. Use of the factory furnished socket weld end cap option should be considered to retain the stated valve pressure rating.

MATERIALS OF CONSTRUCTION

No.	PART NAME	MATERIAL
1	BODY	WCB CF8M
2	END CAPS	WCB CF8M
3	BALL	CF8M / 316
4	STEM	316SS
5	SEAT	TFM 4215 (R-PTFE)
6	BODY - CAP GASKET	GRAPHITE
7	CAP SCREW	B7M B8
9	ANTI - STATIC SPRING	316SS
10	ANTI - STATIC BALL	316SS
11	THRUST WASHER	PTFE (15% G)
12	STEM O-RING	VITON
13	STEM PACKING	GRAPHITE
14	GLAND RING	304SS
15	STOP SCREW	304SS
16	STEM NUT	304SS
17	LOCK WASHER	304SS
18	LEVER	304SS
19	BELLEVILLE SPRING WASHER	301SS
20	PLASTIC SLEEVE	VINYL

DIMENSIONS

SIZE (inches)	Pressure Rating psi	A	B	C	D	F	G	I	J	J1	SW	d1	d2	H	L	Cv	ISO Pad	Wt. (LBS)
1/2	2000	.63	2.95	2.79	4.33	.855	.99	.38	1.42	1.65	.35	.24	.24	1.67	.31	12	F03, F04	1.8
3/4	2000	.79	3.15	2.89	4.33	1.07	1.09	.50	1.42	1.65	.35	.24	.24	1.76	.31	31	F03, F04	2.2
1	2000	.96	3.54	3.31	5.31	1.33	1.30	.50	1.65	1.97	.43	.24	.28	2.13	.39	45	F04, F05	3.8
1 1/4	2000	1.26	4.33	3.52	5.31	1.68	1.62	.50	1.65	1.97	.43	.24	.28	2.33	.39	77	F04, F05	6.9
1 1/2	1500	1.50	4.72	4.31	6.50	1.92	1.94	.50	1.97	2.76	.55	.28	.35	2.86	.58	116	F05, F07	8.1
2	1500	1.97	5.51	4.68	6.50	2.41	2.50	.62	1.97	2.76	.55	.28	.35	3.26	.58	266	F05, F07	14.3

QUALITY MANAGEMENT SYSTEM

CERTIFIED BY DNV

ISO 9001:2008

International Standard Valve, Inc.

ISV Series No. BF2E-F ASME Code Compliant

Distributed by:

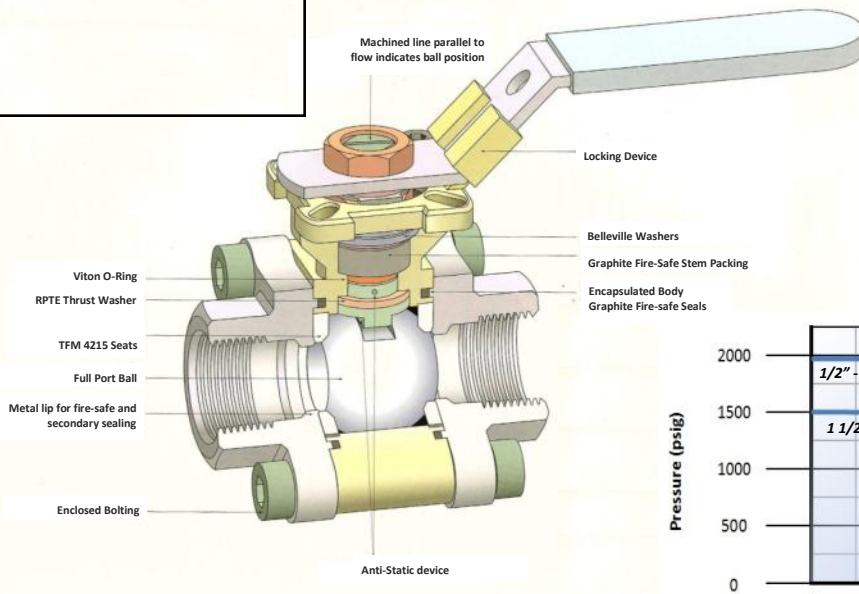

Pressure—Temperature Chart

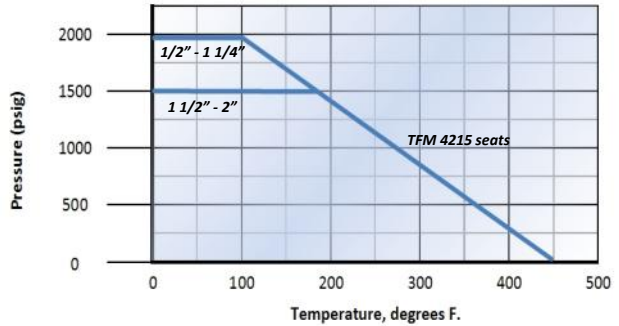

Specifying ISV Series No. BF2E-F

Example: ISV figure number **BF2E-FW20-1236TH-CV-NFL**

Describes a 2000 PSIG, three piece bolted body design, adjustable stem packing design, floating type ball valve, full port, female threaded ends, with WCB body material, 316SS ball & stem, TFM 4215 seat (R-PTFE), Viton seals, meets NACE, fire safe tested per API 607 with locking lever operator.

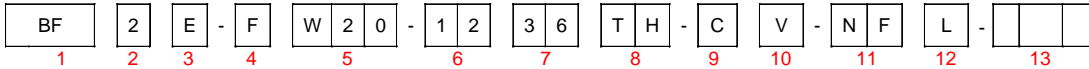

1. Valve Type		2. Service /Design Style		3. Body Design		4. Bore		5. Working Pressure		6. Body Material	
Code	Description	Code	Description	Code	Description	Code	Description	Code	W.O.G.	Code	Description
BT	Ball Valve Trunnion	0	Adjustable Packing- (Commercial Design)	A	1 pc End Entry	R	Reduced	W06	600 W.P.	11	A105N
BF	Ball Valve Floating	1	Adjustable Packing- Flanged (API 608, ASME B16.34)	B	2 pc Split- Bolted	F	Full	W08	800 W.P.	12	WCB
BFM3L	3-Way, L-Port, Floating Ball			C	2 pc Threaded			W10	1000 W.P.	22	LF2
BFM3T	3-Way, T-Port, Floating Ball	2	Adjustable Packing THRD, SW, NIPPLE, B W Ends (API 608, ASME B16.34)	D	2 pc Seal Weld			W15	1500 W.P.	24	LCC
BFM4L	4-Way, L-Port, Floating Ball			E	3 pc Bolted			W20	2000 W.P.	34	304SS / CF8
BFM4T	3-Way, T-Port, Floating Ball	3	O-Ring Stem Seal	F	3 pc Threaded			W21	2160 W.P.	36	316SS / CF8M
		4	Metal Seated Valve	G	3 pc Welded			W22	2200 W.P.	71	Monel
								W30	3000 W.P.		
								W36	3600 W.P.		
								W60	6000 W.P.		
7. Trim Material		8. End Connections		9. Seat		10. Seal		11. Features		12. Operator	
Code	Description	Code	Description	Code	Description	Code	Description	Code	Description	Code	Description
10	C.S. + ENP	TH	Female Threaded	N	Nylon	V	Viton	NF	NACE compliant, Fire Safe Tested	L	Locking Lever
34	304SS / CF8	SW	Female Socket weld	T	PTFE	H	HNBR	NW	NACE compliant, Non-Fire Tested	B	Bare Stem Actuated
36	316SS / CF8M *	WW	WE x WE	D	Devlon	L	Low Temp. (-50 F.) O-Ring			A	Actuated
71	Monel	WF	WE x Flange	H	HNBR	P	PEEK	WF	Without NACE, Fire Safe Tested	G	Manual Gear Lever
		ST	Fem. SW x TH	R	R-PTFE	G	Graphite			H	Non-locking Lever
		ES	Extended End Female SW	C	TFM 4215 (R-PTFE)	T	PTFE	WW	Without NACE Non-Fire Tested	C	Chain Wheel
				M	TFM 4105 (R-PTFE)	M	TFM			O	Oval Hand wheel
				J	TFM 1600 (PTFE)	E	EPDM			S	Spring Return Lever
				P	PEEK	F	Delrin				
				E	EPDM	K	Kel-F				
				F	Delrin	1	Metal				
				1	Metal						
13. Modifier Code											
Code	Description										
	Special configurations										

* Ball and/or stem may be furnished as 17-4ph stainless steel for improved hardness and durability.

* Devlon is a registered trademark of the James Walker company



is a registered trademark of International Standard Valve, Inc.

10749 Cash Road, Stafford, Texas 77041 713-983-7600

www.isvalve.com

sales@isvalve.com

Bulletin No. SB440.4 Issue 03/21/2016